

Installation Manual for the

MIGHTY MULE **502** **E-Z GATE OPENER™** **UL325 SERIES**



DUAL GATE SYSTEM

⚠ WARNING! ⚠

This equipment is similar to other gate or door equipment and meets or exceeds Underwriters Laboratory Standard 325 (UL 325). However, gate equipment has hazards associated with its use and therefore by installing this product the installer and user accept full responsibility for following and noting the installation and safety instructions. Failure to follow installation and safety instructions can result in hazards developing due to improper assembly. You agree to properly install this product and that if you fail to do so GTO, Inc. shall in no event be liable for direct, indirect, incidental, special or consequential damages or loss of profits whether based in contract tort or any other legal theory during the course of the warranty or at any time thereafter. The installer and/or user agree to assume responsibility for all liability and use of this product releasing GTO, Inc. from any and all liability. If you are not in agreement with this disclaimer or do not feel capable of properly following all installation and safety instructions you may return this product for full replacement value.

READ ALL INSTRUCTIONS CAREFULLY AND COMPLETELY before attempting to install and use this automatic gate opener. This gate opener produces a high level of force. Stay clear of the unit while it is operating and exercise caution at all times.

All automatic gate openers are intended for use on vehicular gates only.

This product meets and exceeds the requirements of UL 325, the standard which regulates gate opener safety, as established and made effective March 1, 2000, by Underwriters Laboratories Inc.



3121 Hartsfield Road • Tallahassee, Florida, USA 32303
Telephone GTO Sales: 1-800-543-GATE (4283) or (850) 575-0176 • Fax (850) 575-8912
or GTO Technical Service: 1-800-543-1236 or (850) 575-4144 • Fax (850) 575-8950
www.mightymule.com

R502INST
rev - 12/09/04

The Mighty Mule® Gate Opener is intended for use with vehicular swing gates. The opener can be used in Class I, Class II, Class III and Class IV applications.

VEHICULAR GATE OPENER CLASS CATEGORIES

Residential Vehicular Gate Opener-Class I: A vehicular gate opener (or system) intended for use in a home of one-to-four single family dwelling, or a garage or parking area associated therewith.

Commercial/General Access Vehicular Gate Opener-Class II: A vehicular gate opener (or system) intended for use in a commercial location or building such as a multifamily housing unit (five or more single family units), hotel, garages, retail store, or other building servicing the general public.

Industrial/Limited Access Vehicular Gate Opener–Class III: A vehicular gate opener (or system) intended for use in an industrial location or building such as a factory or loading dock area or other locations not intended to service the general public.

Restricted Access Vehicular Gate Opener–Class IV: A vehicular gate opener (or system) intended for use in a guarded industrial location or building such as an airport security area or other restricted access locations not servicing the general public, in which unauthorized access is prevented via supervision by security personnel.

Conversion Chart

<i>Converting Metric Units to English Equivalents</i>			
When You Know	Multiply By	To Find	Symbol
centimeters	0.3937	inches	in. (or ")
meters	3.2808	feet	ft. (or')
kilograms	2.2046	pounds	lb. (or #)
<i>Converting English Units to Metric Equivalents</i>			
When You Know	Multiply By	To Find	Symbol
inches	2.5400	centimeters	cm
feet	0.3048	meters	m
pounds	0.4535	kilograms	kg
<i>Converting Temperature</i>			
deg. Celsius	$(^{\circ}\text{C} \times 1.8) + 32$	deg. Fahrenheit	$^{\circ}\text{F}$
deg. Fahrenheit	$(^{\circ}\text{F} - 32) \div 1.8$	deg. Celsius	$^{\circ}\text{C}$

FOR YOUR RECORDS

Please record the product serial number (located on the control box cover), and the date and place of purchase in the spaces provided below. Refer to this information when calling GTO for service or assistance with your automatic gate opener.

Serial Number _____ **Date of Purchase** _____

Place of Purchase _____

Remember to keep all receipts for proof of purchase.

Table of Contents

Gate Opener Class Categories	inside cover
Units and Standards Conversion Chart	inside cover
PLEASE READ THIS FIRST!	page iii
Important Safety Instructions	page 1
Disconnecting the Opener	page 1
Important Safety Instructions for the Consumer	page 2
Secondary Means of Protection Against Entrapment	page 5
Required Safety Precautions for Gates	page 6
Warning Signs and Labels	page 7
Installation	page 8
Parts List	page 8
Technical Specifications	page 10
Installation Overview	page 11
Installation of the Mounting Hardware	page 12
Mounting the First Opener	page 16
Installing the Second Opener	page 16
Installation of the Closed Position Stops	page 17
Mounting the Control Box	page 19
Connecting the Opener Power Cables	page 20
Powering the System	page 21
Solar Chart	page 21
Connecting the Transformer	page 21
Control Board Settings	page 24
Obstruction Sensitivity	page 25
Main DIP Switches	page 26
Dual Mode DIP Switches	page 27
Setting Closed Position Limits	page 28
Setting Your Personal Transmitter Code	page 27
Installing the Receiver	page 28
Connecting Additional Safety Devices	page 29
Connecting Accessories	page 31
Push to Open Installation	page 32
Setting Open Position Limits	page 33
Maintenance & Troubleshooting Guide	page 35
Warranty and Repair Service	page 37
Column Installation Information	page 38
Accessory Catalog	page 39

KEEP THESE INSTRUCTIONS FOR FUTURE REFERENCE



PLEASE READ THIS FIRST!

Thank you for purchasing a **Mighty Mule® E-Z Gate® Opener**—GTO's "do-it-yourself" automatic gate opener! When correctly installed and properly used, your **Mighty Mule® E-Z Gate® Opener** will give you many years of reliable service. Please read the following information and watch the enclosed videotape to ensure you have the correct system for your particular needs. Furthermore, this manual and the videotape will enable you to properly install your **Mighty Mule® E-Z Gate® Opener**.

The **Mighty Mule® E-Z Gate® Opener** is designed for installation on a **pull-to-open dual leaf gate** (gates that open *into* the property). By purchasing an *accessory bracket*, the **Mighty Mule® E-Z Gate® Opener** can accommodate a **push-to-open dual leaf gate** (gates that open *out* from the property). The gate must not exceed 18 feet in length and weigh more than 350 pounds per leaf or exceed 6 feet in length and weigh more than 850 pounds per leaf (please see *Technical Specifications* on page 10). The **Mighty Mule® E-Z Gate® Opener** can be used on vinyl, aluminum, chain link, farm tube, and wrought iron gates. Use on solid (wood) gates is not recommended. Solid surface gates have a high resistance to the wind. If the wind is strong enough, the opener will obstruct and stop.

The **Mighty Mule® E-Z Gate® Opener** accommodates extra transmitters, digital keypads, solar panels, push buttons, automatic gate locks, and other access control products. These optional accessories (see the enclosed *Mighty Mule® Accessory Catalog*) are available at most stores. Your store should be able to special order any accessory not in stock. If your store cannot special order accessories, please call the GTO Sales Department (800-543-GATE).

The **Mighty Mule® E-Z Gate® Opener** features **adjustable obstruction sensing**. This safety feature makes the gate stop and reverse direction within 2 seconds when it comes in contact with an obstruction. **MIN** is the factory setting; meaning the gate will exert the minimum force on an obstruction before it stops and reverses direction.

The **Mighty Mule® E-Z Gate® Opener** also has an **adjustable auto-close feature**. After the gate reaches the fully open position, it can be set to remain open up to 120 seconds before automatically closing. Pressing the transmitter button at any time after the gate opens fully will cause it to close immediately. **OFF** is the factory setting; meaning the gate will stay open until you press the transmitter (or keypad, etc.) again.

PLEASE NOTE—If your application requires any of the following:

- Swing gates longer than 18 feet or weighing more than 850 pounds;
- Slide gates;
- Heavy duty or commercial uses;
- Professional installation;

please call GTO at **(800) 543-GATE [4283]** or **(850) 575-0176** for information about our **GTO/PRO** professional line of gate openers and accessories. Our Sales Department will be glad to give you the name and phone number of a **GTO/PRO** dealer near you.

BEFORE YOU BEGIN TO INSTALL YOUR AUTOMATIC GATE OPENER:
watch the enclosed videotape and read these instructions *carefully and completely*
to become familiar with all parts and installation steps. The video tape is only designed as a
overview of the installation procedure. You must read the installation manual for detailed
instructions on gate opener safety and proper use of the gate opener.



IMPORTANT SAFETY INSTRUCTIONS



Because automatic gate openers produce high levels of force, consumers need to know the potential hazards associated with improperly designed, installed, and maintained automated gate opener systems. **Keep in mind that the gate opener is just one component of the total gate operating system.** Each component must work in unison to provide the consumer with convenience, security, and safety.

This manual contains various safety precautions and warnings for the consumer. Because there are many possible applications of the gate opener, the safety precautions and warnings contained in this manual cannot be completely exhaustive in nature. They do, however, provide an overview of the safe design, installation, and use of this product. **CAREFULLY READ AND FOLLOW ALL SAFETY PRECAUTIONS, WARNINGS, AND INSTALLATION INSTRUCTIONS TO ENSURE THE SAFE SYSTEM DESIGN, INSTALLATION, AND USE OF THIS PRODUCT.**

Precautions and warnings in this manual are identified with this  warning symbol. The symbol identifies conditions that can result in damage to the opener or its components, serious injury, or death.

Because GTO automatic gate openers are *only part of the total gate operating system*, it is the responsibility of the consumer to ensure that the total system is safe for its intended use.

To Manually Open and Close the Gate, Follow the Procedure Below:

 **CAUTION:** The gate will move freely and uncontrolled when the gate opener is removed from the gate. **ONLY** disconnect the opener when the control box power switch is **OFF** and the gate is **NOT** moving.

Disconnecting the Opener

1. Turn control box power switch **OFF**.
2. Remove hairpin clip, clevis pin, and bushing from either the front or rear mounting point.
3. Remove the opener from the mount.

The gate can be opened and closed manually when the opener is disconnected.

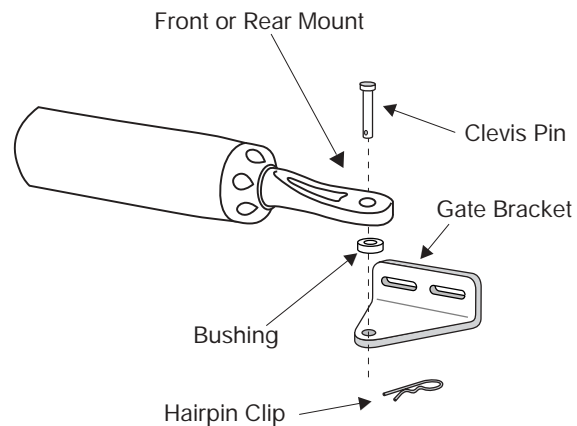

NOTE: Substitute a **Pin Lock** for the clevis pin on the front mount of each gate opener to prevent unauthorized removal of the opener from the gate (*see Accessory Catalog*).

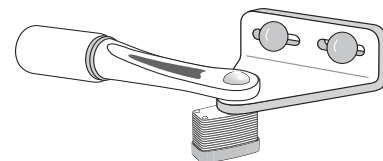



IMPORTANT SAFETY INSTRUCTIONS



For The Consumer

WARNING: To reduce the risk of injury or death:

1. **READ AND FOLLOW ALL INSTRUCTIONS.** Failure to meet the requirements set forth in the instruction manual could cause severe injury and/or death, for which the manufacturer cannot be held responsible.
2. When designing a system that will be entered from a highway or main thoroughfare, make sure the system is placed far enough from the road to prevent traffic congestion.
3. The gate must be installed in a location that provides adequate clearance between it and adjacent structures when opening and closing to reduce the risk of entrapment. Swinging gates **must not** open into public access areas.
4. The gate and gate opener installation **must comply with any applicable local codes.**

I. Before Installation

1. Verify this dual opener is proper for the type and size of gate, its frequency of use and the proper class rating.
2. Make sure the dual gate has been properly installed and swings freely in both directions. Repair or replace all worn or damaged gate hardware prior to installation. A freely moving gate will require less force to operate and will enhance the performance of the opener and safety devices used with the system.
3. Review the operation of the system to become familiar with its safety features. Understand how to disconnect the opener for manual gate operation (*see page 1*).
4. This gate opener is intended for **vehicular gates ONLY**. A separate entrance or gate must be installed for pedestrian use (*see page 6*).
5. Always keep people and objects away from the gate and its area of travel. **NO ONE SHOULD CROSS THE PATH OF A MOVING GATE.**
6. Pay close attention to the diagram below and be aware of these areas at all times.

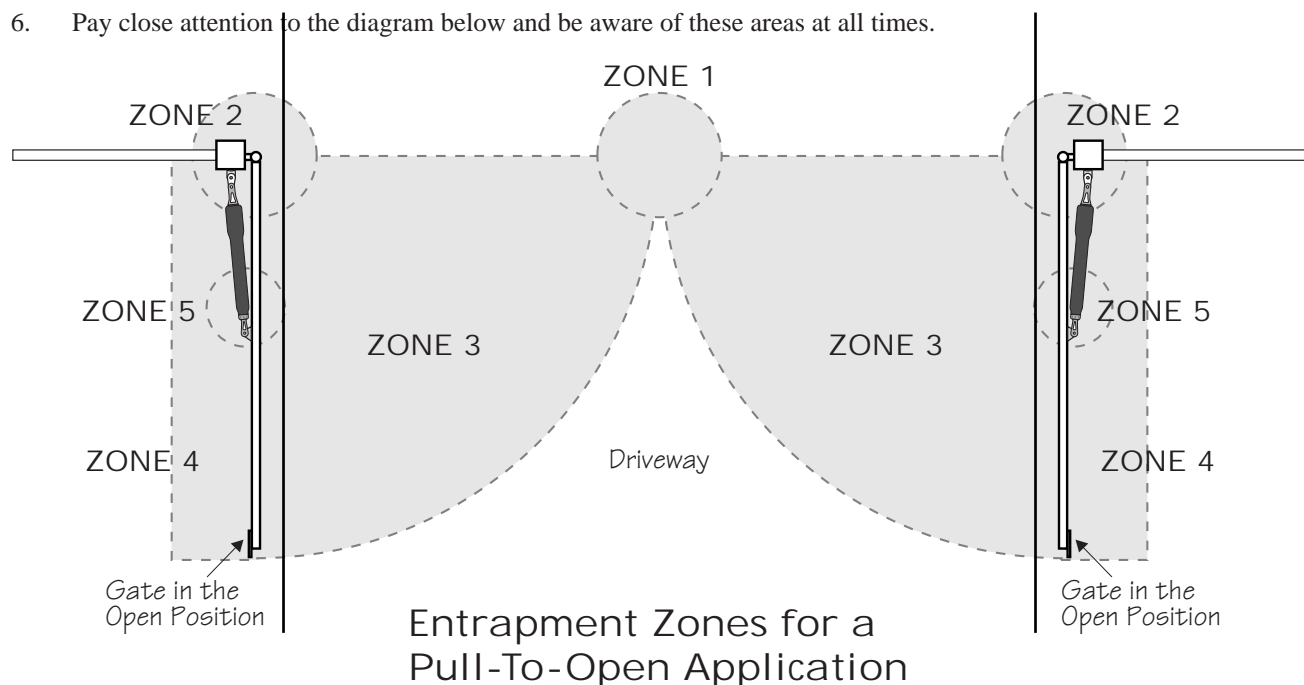



IMPORTANT SAFETY INSTRUCTIONS



Entrapment Zones for a proper Pull-To-Open installation:

Zone 1 – leading edge of the gate and the fence post.

Zone 2 – between the gate and the gate post.

Zone 3 – the path of the gate.

Zone 4 – the space between the gate in the open position and any object such as a wall, fence, tree, etc.

Zone 5 – pinch points between the opener and gate or post.

II. During Installation

1. Install the gate opener on the inside of the property and fence line. **DO NOT** install an opener on the outside of the gate where the public has access to it.
2. Be careful with moving parts and avoid close proximity to areas where fingers or hands could be pinched.
3. Devices such as contact sensors (safety edges) and non contact sensors (photo beams) provide additional protection against entrapment.
4. If push buttons or key switches are installed, they should be within sight of the gate, yet located at least 10 feet from any moving part of the gate (see diagram below). *Never install any control device where a user will be tempted to reach through the gate to activate the gate opener.*
5. Do not activate your gate opener unless you can see it and can determine that its area of travel is clear of people, pets, or other obstructions. Watch the gate through its entire movement.
6. Secure outdoor or easily accessed gate opener controls in order to prohibit unauthorized use of the gate.

Pull-To-Open Application

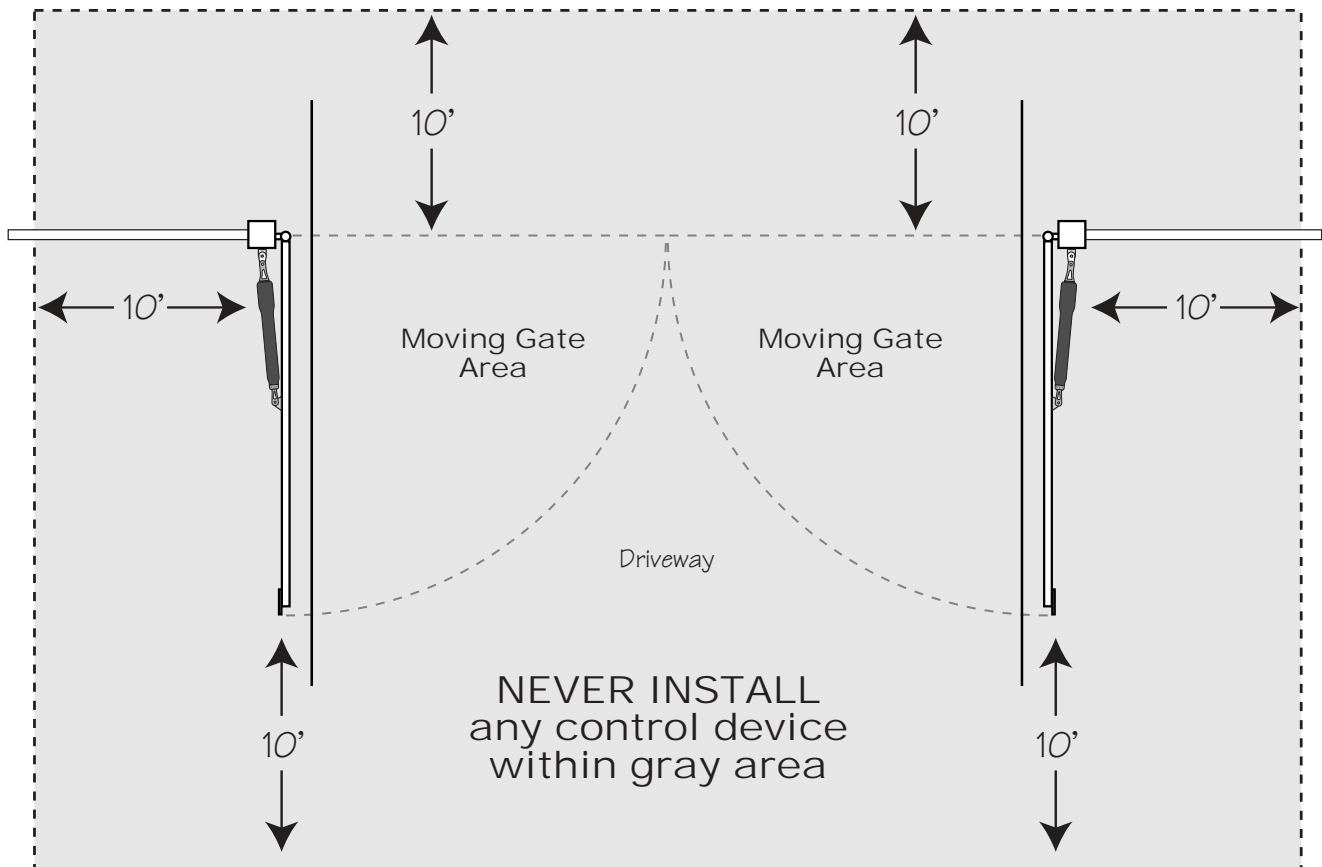



IMPORTANT SAFETY INSTRUCTIONS



III. After Installation

1. Attach the **warning signs** (*included*) to each side of the gate to alert the public of automatic gate operation. It is *your responsibility* to post warning signs on both sides of your gate. If any of these signs or warning decals become damaged, illegible or missing, replace them immediately. Contact GTO for free replacements.
2. The gate is automatic and could move at any time, posing a serious risk of entrapment. No one should be in contact with the gate when it is moving or stationary.
3. Do not attempt to drive into the gate area while the gate is moving; wait until the gate comes to a complete stop.
4. Do not attempt to "beat the gate" while the gate is closing. This is extremely dangerous.
5. Do not allow children or pets near your gate. **Never let children operate or play with gate controls.** Keep the remote controls away from children and unauthorized users; store controls where children and unauthorized users do not have access to them.
6. **KEEP GATES PROPERLY MAINTAINED.** Always turn power to opener OFF before performing any maintenance. Clean the push-pull tube with a soft, dry cloth and apply silicone spray to it at least once per month.
7. Service the gate and gate opener regularly. Grease hinges, and replace the battery every 3-5 years.
8. To operate this equipment safely, YOU must know how to disconnect the opener for manual gate operation (*see page 1*). If you have read the instructions and still do not understand how to disconnect the opener, contact the GTO Service Department.
9. Disconnect the opener **ONLY** when the power is **TURNED OFF** and the gate is **NOT** moving.
10. Make arrangements with local fire and law enforcement for emergency access.
11. Distribute and discuss copies of the **IMPORTANT SAFETY INSTRUCTIONS** section of this manual with all persons authorized to use your gate.
12. **IMPORTANT: Save these safety instructions. Make sure everyone who is using or will be around the gate and gate opener are aware of the dangers associated with automated gates. In the event you sell the property with the gate opener or sell the gate opener, provide a copy of these safety instructions to the new owner.**

Should you lose or misplace this manual, a copy can be obtained by downloading one from the Mighty Mule® web site (www.mightymule.com), by contacting GTO, Inc., at 3121 Hartsfield Road, Tallahassee, Florida 32303 or by calling 1-800-543-4283 and requesting a duplicate copy. One will be provided to you free of charge.



IMPORTANT SAFETY INSTRUCTIONS



Secondary Means of Protection Against Entrapment

As specified by Gate Operator Safety Standard, UL 325 (30A.1.1), automatic gate openers shall have an inherent entrapment sensing system, and shall have *provisions for, or be supplied with*, at least one independent secondary means to protect against entrapment. The Mighty Mule® utilizes **Type A**, an inherent (i.e., built-in) entrapment sensing system as the *primary* type of entrapment protection. Also, the Mighty Mule® has *provisions for* the connection of **Type B2** protection to be used as the *secondary* type of entrapment protection, if desired.

1. For gate operators utilizing a contact sensor (e.g., safety edge sensor– Type B2) in accordance with UL 325 (51.8.4 [i]):

- A. One or more contact sensors shall be located at the leading edge, bottom edge, and post edge, both inside and outside of a vehicular swing gate system.
- B. A hard wired contact sensor shall be located and its wiring arranged so that the communication between the sensor and the gate opener is not subjected to mechanical damage.
- C. A wireless contact sensor such as one that transmits radio frequency (RF) signals to the gate opener for entrapment protection functions shall be located where the transmission of the signals are not obstructed or impeded by building structures, natural landscaping or similar obstruction. A wireless contact sensor shall function under the intended end-use conditions.

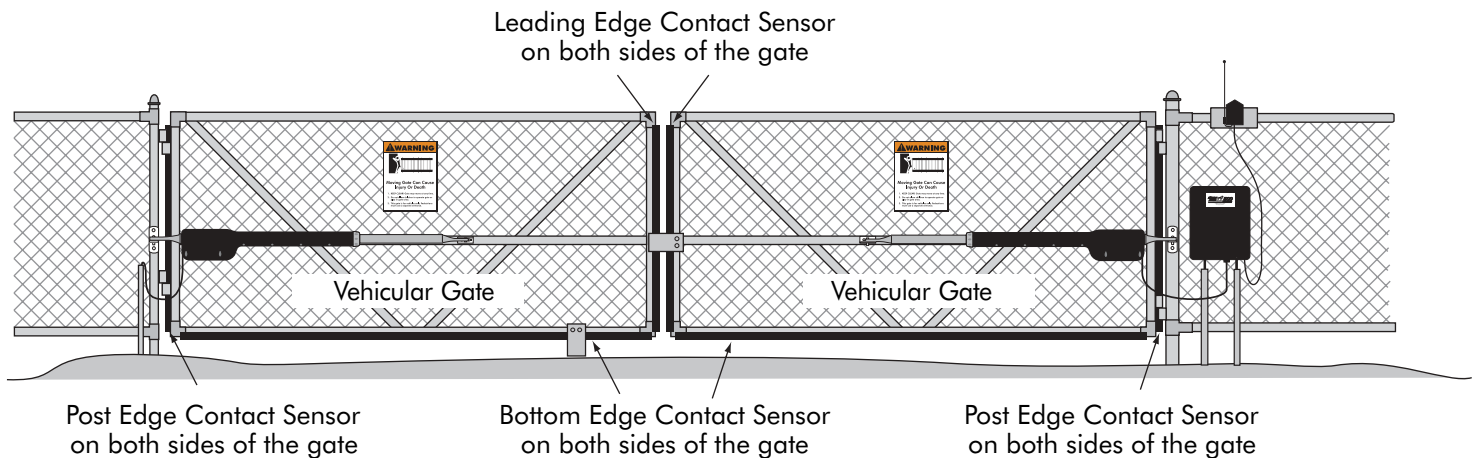

ENTRAPMENT ALARM (UL 325; 30A.1.1A)

The Mighty Mule® E-Z Gate® Opener is designed to stop and reverse within 2 seconds when the gate comes in contact with an obstruction. Additionally, these openers are equipped with an **audio entrapment alarm** which will activate if the unit obstructs *twice* while opening or closing. This alarm will sound for a period of 5 minutes, or until the opener receives an intended signal from a hard wired entry/exit source (e.g. push button control or keypad) and the gate returns to a fully open or fully closed position. Turning the power switch on the control box OFF and back ON will also deactivate the alarm. Wireless controls such as transmitters and wireless keypads will not deactivate the alarm.



IMPORTANT SAFETY INSTRUCTIONS



Required Safety Precautions for Gates Install Warning Signs

Warning signs alert people of automatic gate operation and are **required** when installing the Mighty Mule® E-Z Gate® Opener. Furthermore, a walk-through gate must be installed if pedestrian traffic is expected near the vehicular gate. We recommend using the **GTO Bulldog Pedestrian Gate Lock** (Call the GTO Sales Department) for controlled access.

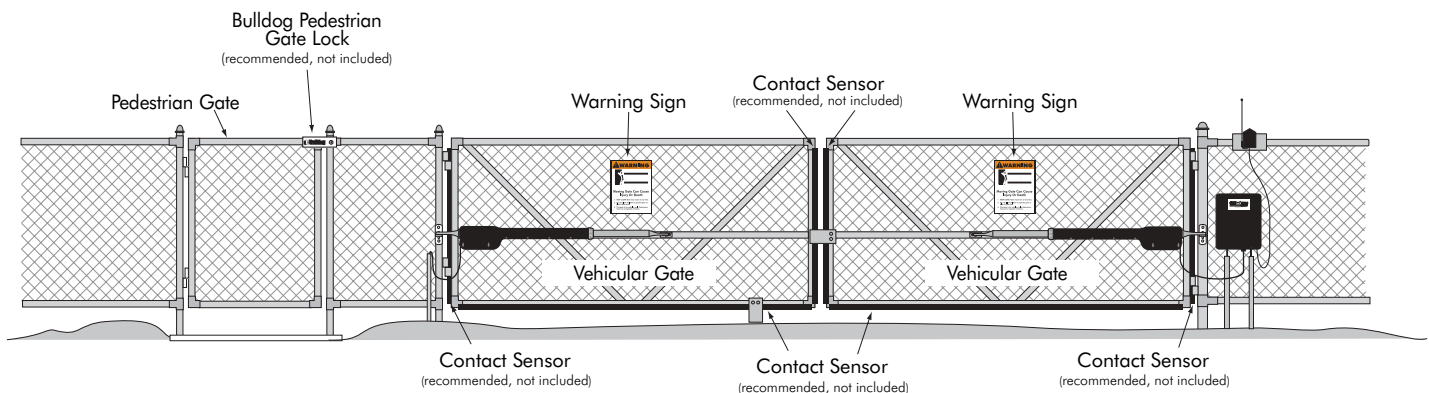

Entrapment Protection

GTO's inherent obstruction settings, even when properly adjusted, **may not be sensitive enough to prevent bodily injury in some circumstances**. For this reason, safety devices such as safety edge sensors (or photoelectric sensors), which stop and reverse gate direction upon sensing an obstruction, are suggested for enhanced protection against entrapment.

Warning Signs

The warning signs (at right) must be installed on both sides of the gates (see page 7 for details).





IMPORTANT SAFETY INSTRUCTIONS



! WARNING

Moving Gate Can Cause Injury Or Death

- 1. KEEP CLEAR! Gate may move at any time.**
- 2. Do not allow children to operate gate or play in gate area.**
- 3. This gate is for vehicles only. Pedestrians must use a separate entrance.**

These warning labels should be found at the locations specified below. If any of them are missing, immediately contact GTO for replacements.

GTO DC SWING SERIES / 500
Conforms to UL 325 STANDARDS
 Maximum Gate: 500 lb. (226.7 kg); 16 ft. (4.8 m)
 Voltage: 12 Vdc; Frequency: 0 Hz; Power: 25 W
 Class I, II, III and IV Vehicular Swing Gate Operator.
 Serial Number: XXXXXXXXX

TO MANUALLY OPEN AND CLOSE THE GATE:

1. Turn control box power switch OFF.
2. Disconnect front or rear mount from gate bracket.
3. Pull opener away from front or rear mount.

Disconnect operator **ONLY** when the control box power switch is **OFF** and the gate is **NOT** moving.

GTO, Inc. Tallahassee, Florida USA

Product identification and manual operation instruction label (1) installed on control box cover

Warning signs (2 enclosed) to be installed on each side of the gate (3—5 feet above the bottom of the gate)

MIGHTY MULE 502

E-Z GATE® OPENER UL325 SERIES

1-800-543-GATE (4283) • www.mightymule.com

! WARNING

MOVING GATE Can Cause Injury or Death

1. KEEP CLEAR! Gate may move at any time.
2. Do not allow children to operate gate or play in gate area.
3. This gate is for vehicles only. Pedestrians must use separate entrance.

Logo and warning labels (2) installed on each side of opener housing

Dual Gate Opener Parts List

Opener and Mounting Hardware

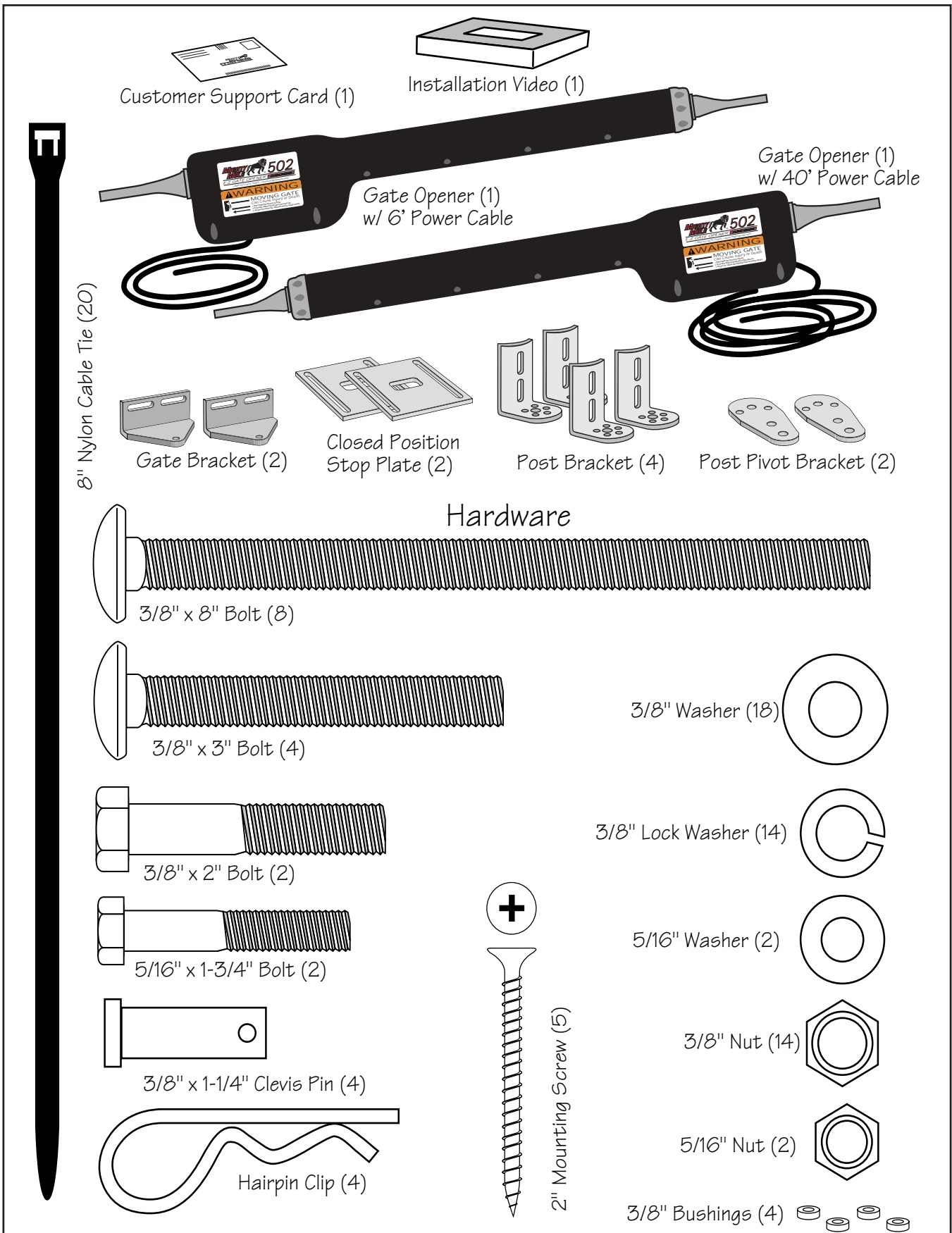

Dual Gate Opener Parts List (continued)

Control Box and Electrical Components

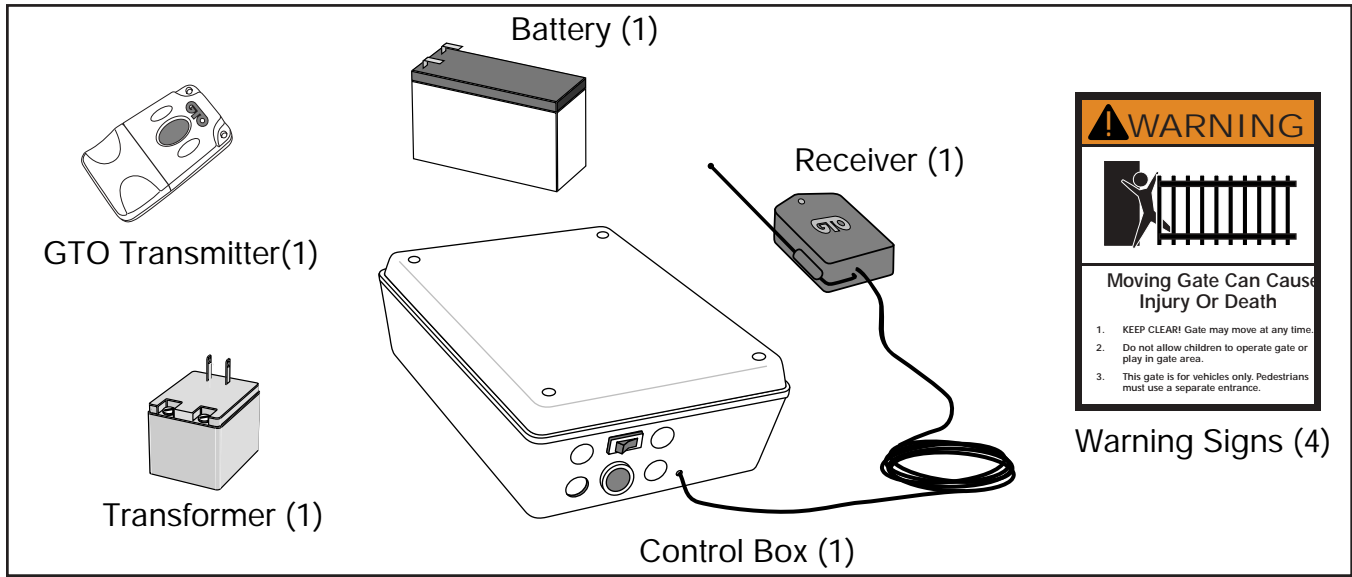

Tools Needed

- Power Drill
- Open End Wrenches — 3/8", 7/16", 1/2", and 9/16"
- 3/8" Drill Bit
- Hacksaw or Heavy Duty Bolt Cutters
- Small (Flat Bladed) Screwdriver
- Phillips Screwdriver
- Tape Measure
- Level
- Wire Strippers
- C-Clamps — small, medium, and large
- Center Punch
- An extra person will be helpful

YOU MAY ALSO NEED THESE ITEMS BEFORE YOU BEGIN THE INSTALLATION

(Some of these items can be found in the *Accessory Catalog* page 39):

- **Low voltage wire** will be needed to run from the transformer to the control box; length depends upon the distance between the transformer power supply and the control box. See **Powering the System** on page 21, and the *Accessory Catalog*.
- If your gate is more than 1000' away from an ac power source you will need to use at least 10 to 30 Watts of solar charging power to trickle charge the battery. See the *Accessory Catalog*.
- If your fence post is made of wood and is less than 6" in diameter or 6" square, see page 12.
- If your fence post is larger than 6" in diameter you will need **threaded rods or carriage bolts longer than 8"**. See page 15.
- PVC conduit.
- If you have thin walled tube or panel gates, see **Recommended Reinforcement Examples** on page 12.
- Depending on the type of gate, a **horizontal cross member or mounting plate may be needed** to mount the front of the opener and gate bracket to the gate. See page 11, step 2; page 15, step 10.
- Surge protection for transformer.
- Some types of installations require U-Bolts.
- If the gate is a push-to-open refer to page 36
- Additional washer or a metal plate may be needed for wooden post.

Technical Specifications

MIGHTY MULE® 502 E-Z GATE® OPENER

DRIVE

- Low friction screw drive (linear actuator) rated for -5 °F to +160 °F (-28 °C to +71 °C).
- Powered by a 12 V motor with integral case hardened steel gear reducer. Motor speed reduced to 260 rpm. Generates 680 ft. lb. of torque at 12 V.
- Maximum opening arc of 110°. Approximate opening time (90°): 20 seconds, depending on weight of gate.

POWER

- The system is powered by a 12 Vdc, 7.0 Ah, sealed, rechargeable acid battery.
- Battery charge is maintained by a 120 Vac, 18 Vac output transformer rectified to 14.5 Vdc (20 VA) through the GTO control board. One (1) blade-style control board fuse rated for 25 A.

NOTE: The transformer should not be directly connected to any battery. Do not replace fuses with higher ampere rated fuses; doing so will void your warranty and may damage your control board.

- Battery charge is maintained by GTO Solar Panel Charger: float voltage of 14.5 Vdc output from a 19³/₈" x 8¹/₂" silicon alloy panel. Generates minimum of 5 W at 300 mA. A gated diode on the control board prevents battery discharge.

CONTROL

- **GTO** microprocessor-based control board is set for single leaf, pull-to-open gate installations. DIP switches can be adjusted to accommodate an optional kit for push-to-open gates (*see Accessory Catalog*).
- Control board has temperature compensated circuits.
- A circuit on the control board regulates charging. "Sleep draw" is 40 mA; "active draw" is 2 to 5 A.
- Auto-memorization of digital transmitter code.
- GTO remote-mounted RF receiver tuned to 318 MHz.
- Opener length with push-pull tube fully retracted is 40¹/₄", mounting point to mounting point.
- Adjustable auto-close timer and obstruction sensitivity.
- Power terminal block accommodates a transformer or solar panels.
- DIP switches simplify setup of gate opener.
- Accessory terminal block is fully compatible with push button controls, digital keypads, safety loops, etc.
- Control board allows connection of safety edge sensors and photoelectric sensors.
- Audio entrapment alarm sounds if the unit encounters an obstruction twice while opening or closing.

OPERATIONAL CAPACITY

- The Gate Capacity Chart shows approximate cycles, per day, you can expect from the Mighty Mule 502 Automatic Gate Operator when powered with a transformer. Actual cycles may vary slightly depending upon the type and condition of gate and installation.

Cycles shown are for a single gate, dual gates will get approximately half as many cycles.

NOTE: "NR" indicates this size and weight combination is not recommended for the Mighty Mule 350.

IMPORTANT: BALL BEARING HINGES SHOULD BE USED ON ALL GATES WEIGHING OVER 250 Lbs.

Mighty Mule 502 Gate Capacity /Cycle Chart

Estimated number of daily cycles, based on use with a transformer and one(1) 12 Volt battery.

Number of Cycles Per Day

	850 lbs.	135	125	NR	NR	NR	NR	NR
	750 lbs.	145	135	125	NR	NR	NR	NR
	650 lbs.	155	145	135	125	NR	NR	NR
	550 lbs.	165	155	145	135	125	NR	NR
	450 lbs.	175	165	155	145	135	125	NR
	350 lbs.	185	175	165	155	145	135	125
	250 lbs.	195	185	175	165	155	145	135
	150 lbs.	205	195	185	175	165	155	145
	100 lbs.	215	205	195	185	175	165	155
	50 lbs.	225	215	205	195	185	175	165
		5' - 6'	8'	10'	12'	14'	16'	18'

Gate Length

To determine the number of cycles the gate opener will perform using solar panels, please see the specifications listed on *page 19* or call **(800) 543-1236** or **(850) 575-4144** for more information.

* An operation cycle is one full opening and closing of the gate.

These specifications are subject to change without notice.

Installation Overview

Pull-to-Open Gates (Gate Opens into the Property)

The diagram shown below is an example of a pull-to-open installation on a chain link fence and dual gates. Mounting the openers on a masonry column requires special procedures; see **Column Installation Information** on page 38 if you intend to mount the openers on columns. Furthermore, if you have push-to-open gates, you will need to purchase two (2) **push-to-open brackets** (see *Accessory Catalog*) to properly configure your system. See **Push to Open Installation** on page 32 before proceeding.

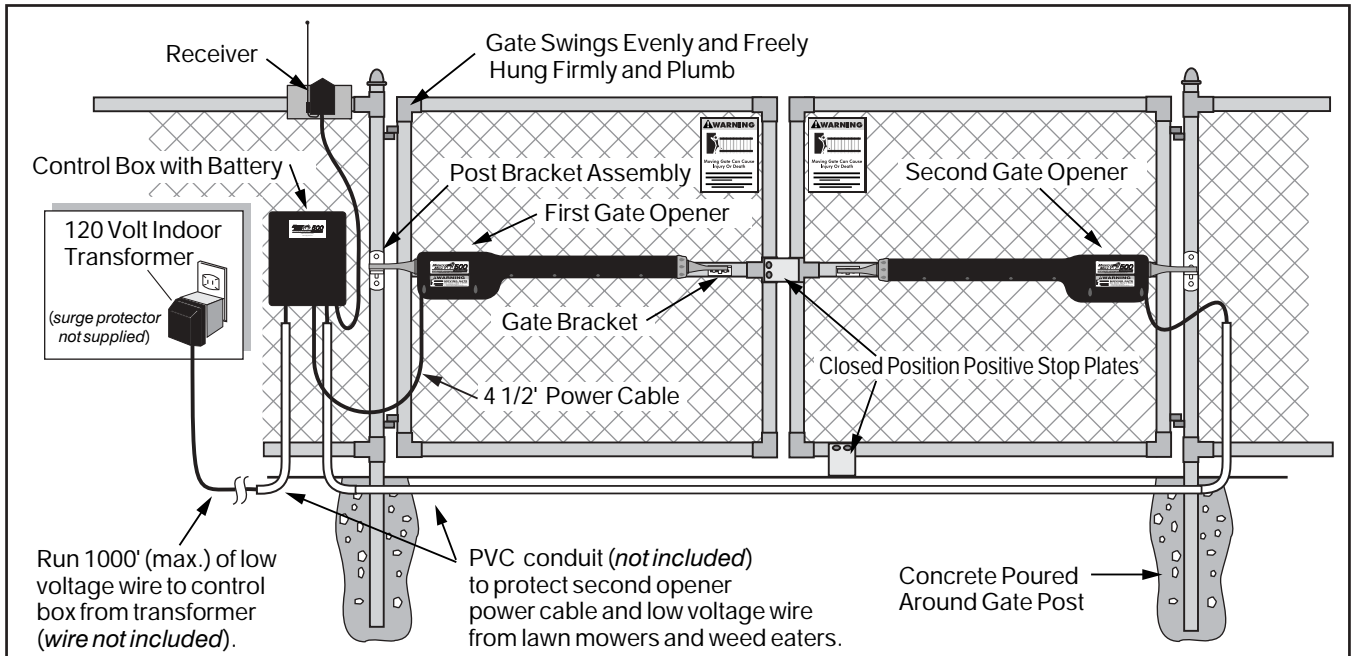

Preparation of the Gate

Step 1

The gates **must** be plumb, level, and swing freely on their hinges. Wheels must not be attached to the gates. The gates must move throughout their arc **without binding or dragging on the ground**. Note that gates over 250 lb. should have ball bearing hinges with grease fittings.

Step 2

The fence posts must be secured in the ground with concrete so they will minimize twist or flex when the openers are activated. We recommend you position the openers near the **centerline** of the gates to keep the gates from twisting and flexing. The addition of **horizontal or vertical cross members** (if they are not already in place) to provide a stable area for mounting the gate brackets is also important.

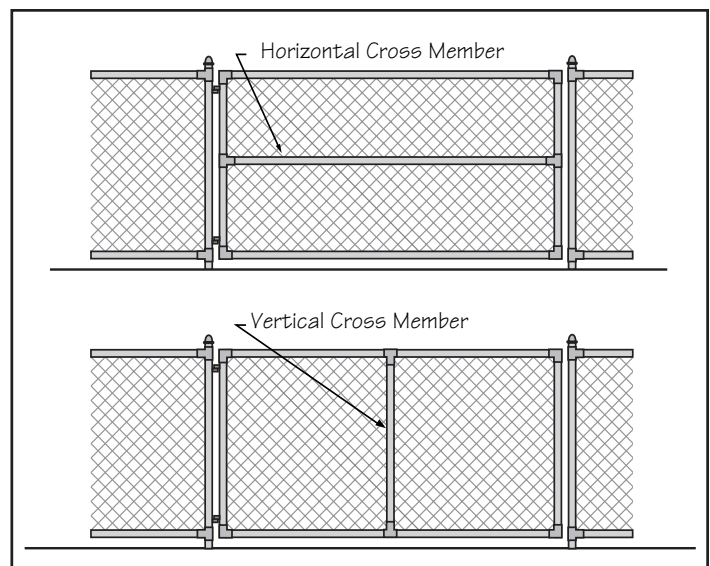

Installation of Mounting Hardware

The position of the post bracket determines the leverage and efficiency of the opener. The post bracket position also sets the clearance between the opener and gate in the open and closed positions (minimum 2 inches).

The curved design of the post bracket works well for installations on round and square fence posts. Because the post bracket carries the entire thrust of the active opener, **bolts that completely penetrate the fence post must be used.**

On wooden posts, place a metal plate or washer (not supplied) between the nuts and the fence post to prevent the thrust of the opener from pulling the bolts and washers out of the wood.

NOTE: A fence post smaller than 6" in diameter or 6" square should be made of metal instead of wood so that it will remain stable while the opener is moving the gate.

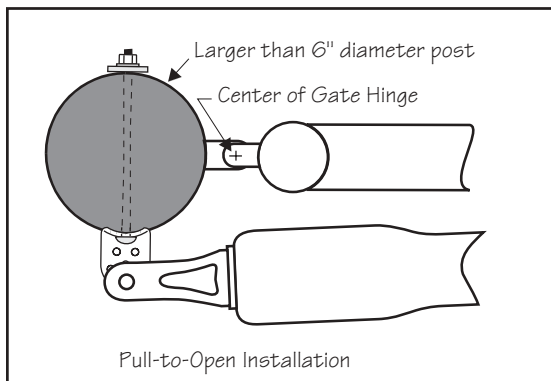
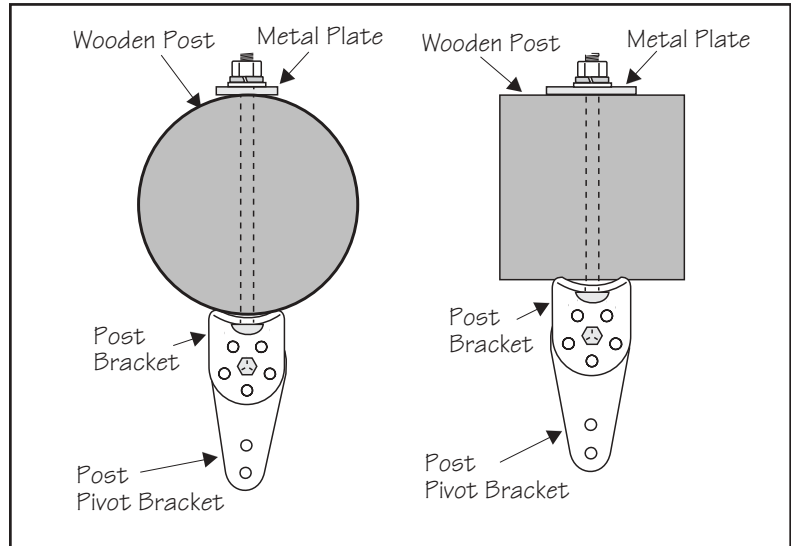

On round posts of 6" diameter or larger, the post pivot bracket may not be necessary for the installation. In this instance, the two post brackets are mounted by themselves.

IMPORTANT:

We **strongly recommend** using steel pipe, wood or metal to reinforce thin walled tube gates or wood to reinforce panel gates as shown. These reinforcement methods will prevent damage to the opener and gate when the opener is installed.

Recommended Reinforcement Examples

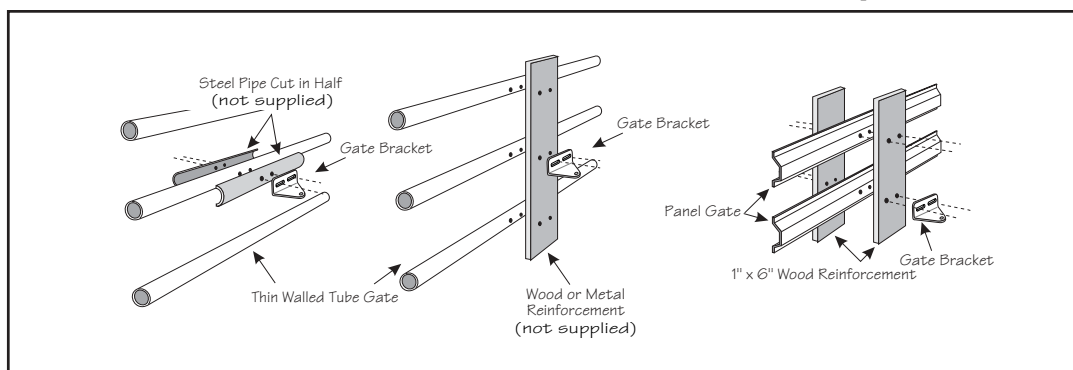

Determining the Mounting Position of the Post Bracket Assembly and the Gate Bracket

Step 3

Insert the $\frac{3}{8}$ " x 2" bolt through the center hole of the post brackets and post pivot bracket as shown. Fasten a $\frac{3}{8}$ " lock washer, $\frac{3}{8}$ " washer and $\frac{3}{8}$ " nut on the end of the bolt. **DO NOT overtighten** the nut because the post pivot bracket will have to be adjusted later.

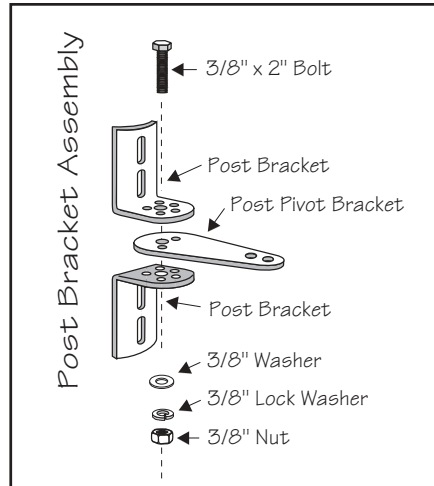

NOTE: The following steps are intended for **pull-to-open** gate installations. If you are mounting your gate openers on a push-to-open gate (e.g., a gate on a sloped driveway) you will need to purchase two **Push To Open** brackets (see *Accessory catalog*). Also, see **Push-to-Open Installation** beginning on page 32.

Step 4

Attach post bracket assembly and gate bracket to the opener with the clevis pins and bushings. Secure the clevis pins with hairpin clips.

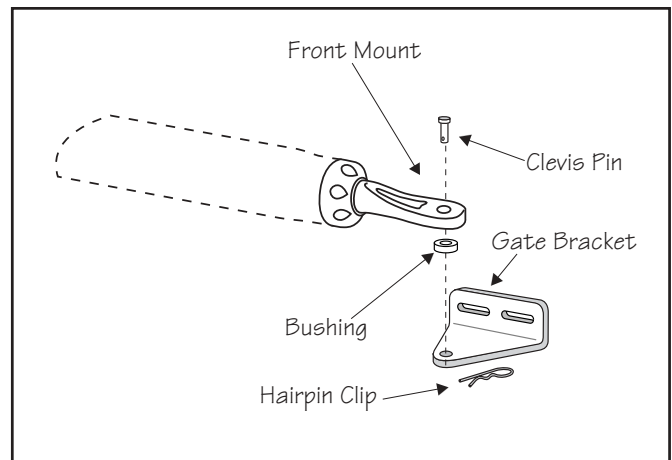
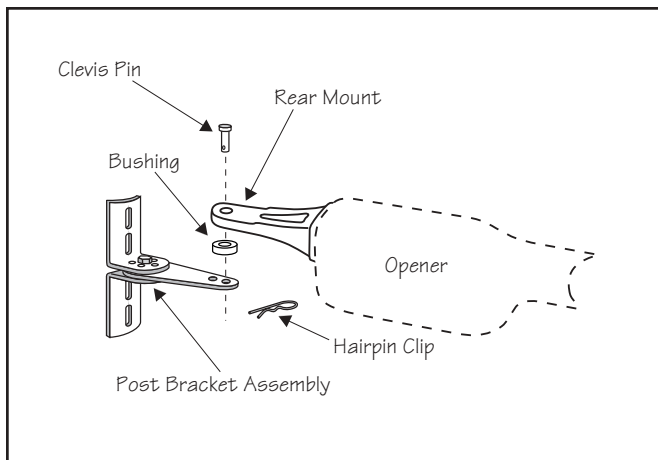

Step 5

With the gate in the open position (up to 110° from its closed position) and the gate opener fully retracted, adjust the post bracket assembly and gate bracket until the opener is level. While holding the opener level, use C-clamps to **temporarily** keep the post bracket assembly and gate bracket in their respective positions on the fence post and gate.

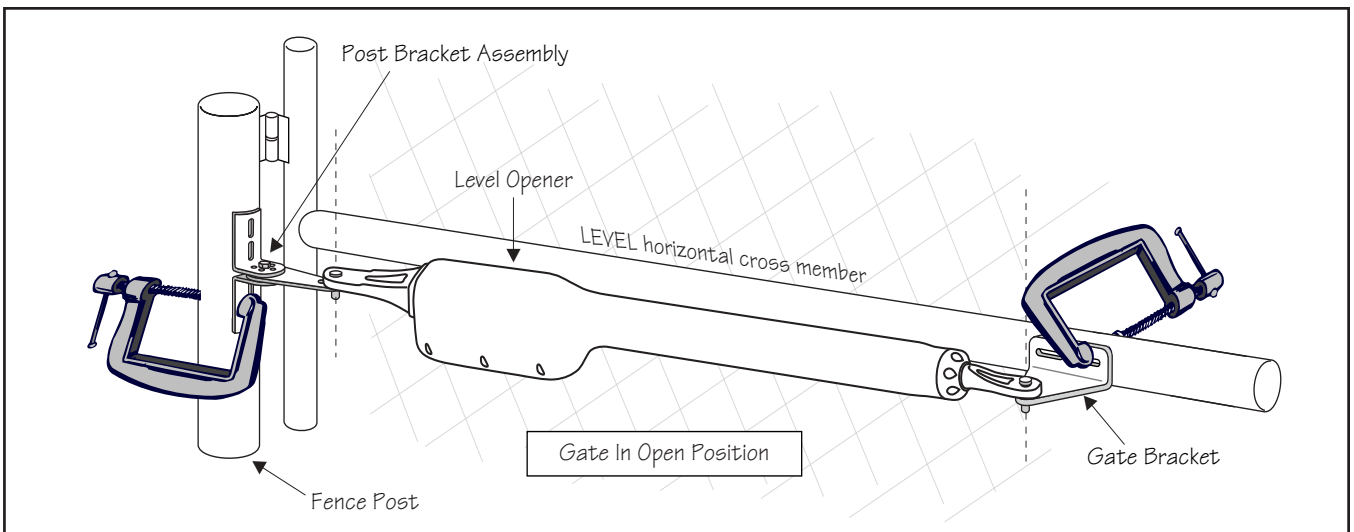

IMPORTANT: While determining the mounting point for the post pivot bracket assembly, be sure that the position allows for minimum 2 inches of clearance between the gate and the opener in both the open and closed positions, as shown in the diagrams below. This clearance will give the opener the most efficient leverage point for opening and closing the gate and more importantly provides the least possible pinch area.

Step 6

When you feel that you have the best position for the post pivot bracket in the open position, insert the 5/16" x 1-3/4" bolt through the aligned holes of the post bracket and post pivot bracket to hold it in place. Remove the clevis pin from the front mount and while supporting the gate opener, swing the gate and gate opener to the closed position. With the gate and gate opener in the closed position check the clearance and be sure that the gate opener is not binding at the post pivot bracket.

If you don't have 2 inches of clearance or the gate opener is binding on the post pivot bracket, remove the 5/16" x 1-3/4" bolt and readjust the pivot bracket until you can achieve these important clearances.

With the post pivot bracket in the optimum position for clearance and freedom of movement, reattach the opener to the gate bracket in the open position and recheck the gate opener level and make sure the brackets are clamped securely.

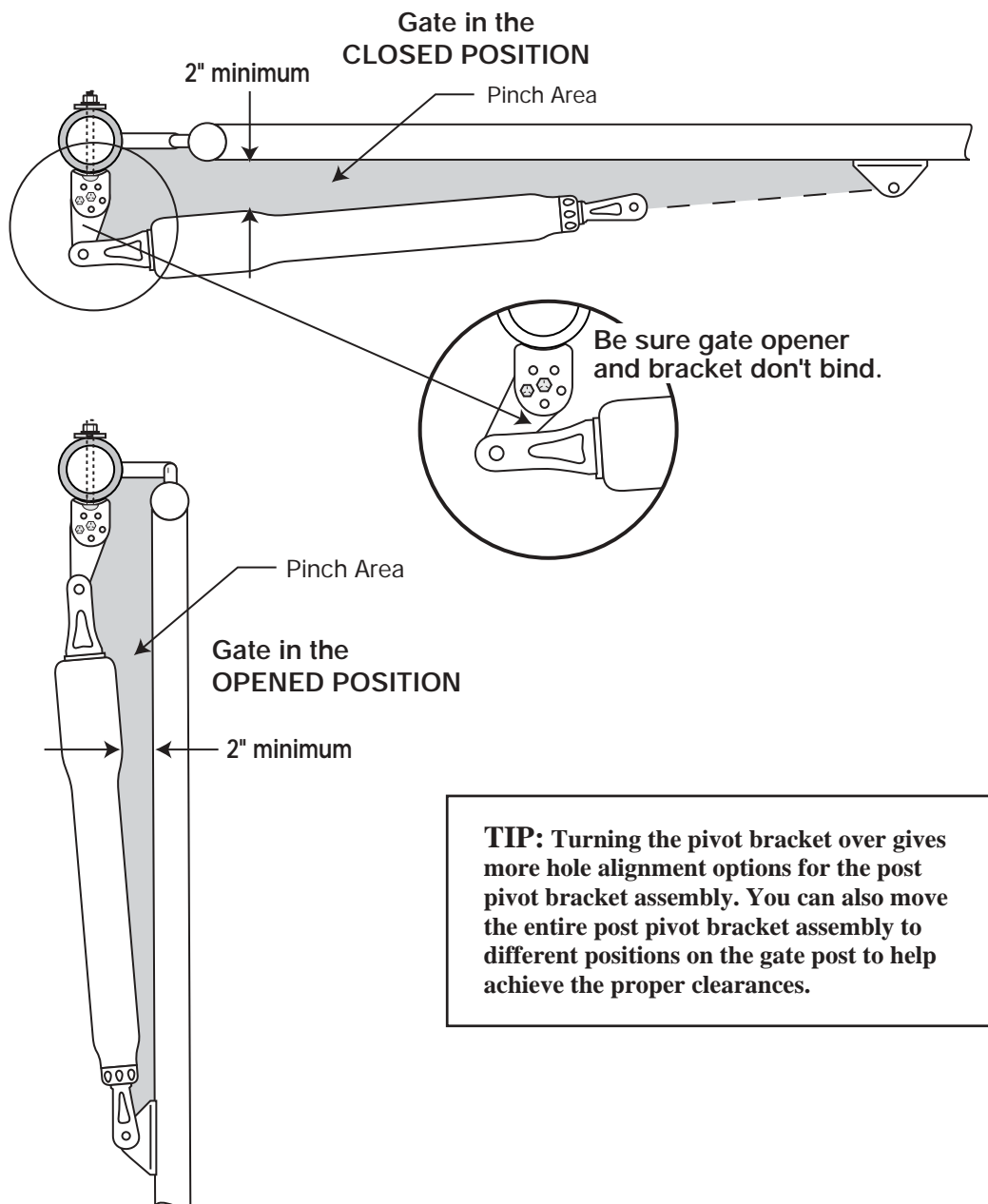

Installing the Post Bracket Assembly and Gate Bracket

Step 7

Mark reference points for bolt holes on the fence post through middle of bracket slots. Marking reference points in this manner allows room for adjustment when mounting the post bracket assembly and gate bracket. After marking your reference points, remove the opener and brackets from the fence and gate.

Step 8

Drill $\frac{3}{8}$ " holes into fence post as marked.

Step 9

Fasten post bracket assembly to the fence post using (4) $\frac{3}{8}$ " x 8" bolts, washers, lock washers, and nuts (*provided*). Remove excess bolt length extending beyond the tightened nuts with a hacksaw or bolt cutters.

NOTE: In cases where the fence post has a diameter larger than 6", **threaded rods or carriage bolts longer than 8"** (*not supplied*) must be used.

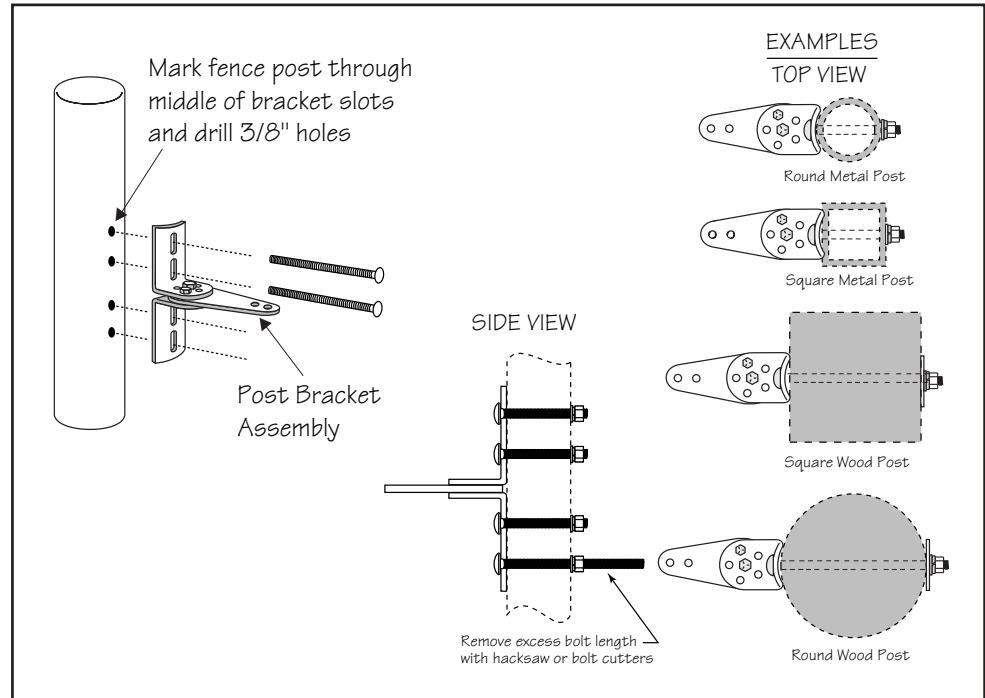

Step 10

Mark reference points for bolt holes on the gate cross member through middle of gate bracket slots. Drill $\frac{3}{8}$ " holes into the gate cross member as marked.

Mount gate bracket using (2) $\frac{3}{8}$ " x 3" bolts, washers, lock washers, and nuts (*provided*). Cut off excess bolt length extending beyond the tightened nuts.

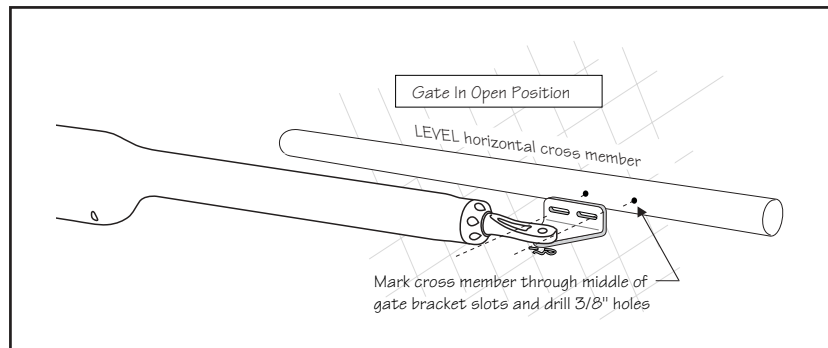

Gate Bracket Mounting Examples

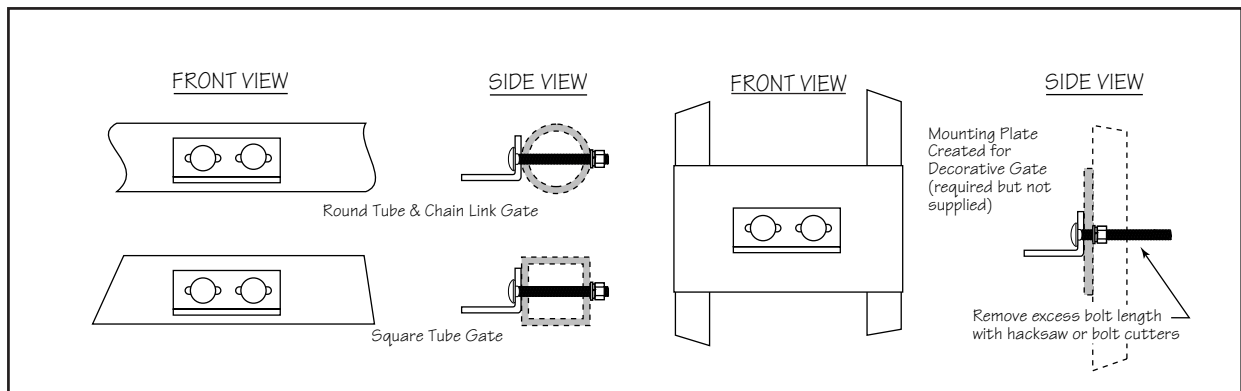

Mounting the First Opener

Step 11

Attach the opener to the securely bolted post bracket assembly and gate bracket using clevis pins, bushings, and hairpin clips, or optional Pin Locks (see *Accessory Catalog*). Verify that the opener is level and adjust the post bracket assembly if necessary.

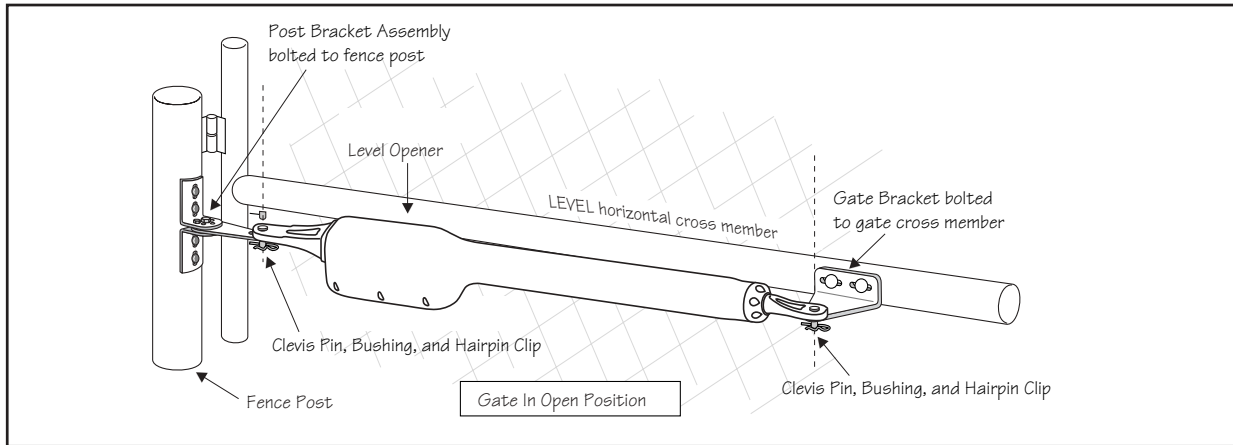

Installing the Second Opener

Step 12

Install the second opener on the remaining gate leaf by repeating **Step 3** through **Step 11**, starting on page 13. After you have mounted the second opener, proceed to **Installing the Positive Stops** on the next page.

Installation of the Closed Position Stops

The Mighty Mule® Gate Openers firmly hold the gates in the closed position using positive stops. The positive stops help stabilize the gate leaves in the closed position. To further enhance stability and security, we strongly recommended using an optional **Mighty Mule® Automatic Gate Lock** (see *Accessory Catalog*) with your dual gate.

IMPORTANT: You need to determine which side of the driveway you will mount the control box. From this point on the gate and gate opener on the same side as the control box will be referred to as the **MASTER** gate and gate opener. The gate and gate opener on the opposite side of the driveway from the control box will be referred to as the **SLAVE** gate and gate opener.

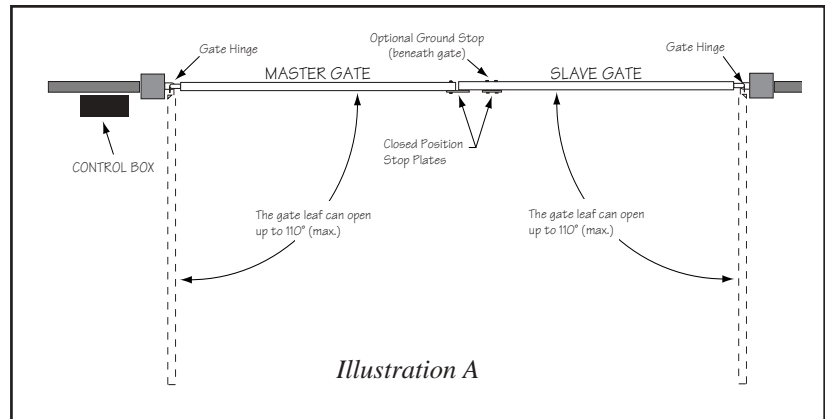

Step 1

Attach the horizontal closed position stop plate to the **MASTER** gate leaf.

Detach the gate operators from the gates and move the gates to their closed position (*Illustration A*). Using appropriate hardware for your type of gate (U-bolts for tube or chain link; screw or bolts for wood or metal) attach the *closed position stop plate* (**horizontally**) about mid height on the **MASTER** gate frame. **Do not** tighten it completely at this time. Slide the stop plate toward the frame of the **SLAVE** gate leaf until they touch (*Illustration B*). Once you have moved the stop plate to the correct position, tighten its hardware completely.

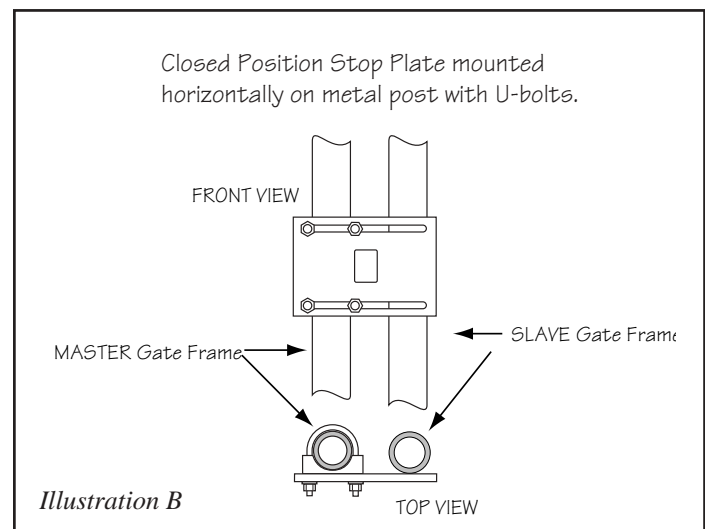

NOTE: The optional ground stop post is used to provide a secure point for the **SLAVE** gate to close against. If you will be using the **GTO/PRO Horizontal Gate Lock** accessory with your gate opener system, the closed position ground stop is **REQUIRED**, as shown in Steps 2 and 3 on the next page.

Step 2

Install a low profile ground stop (*not provided*) beneath the SLAVE gate stop plate.

The ground stop needs to be positioned near the end of the gate as shown in *Illustration A* and may be made of metal or concrete and should be firmly secured in the ground (we recommend setting it in concrete).

Step 3

Attach a vertical closed position stop plate to the SLAVE gate.

Using appropriate hardware for your type of gate attach the vertical *closed position stop plate* to the SLAVE gate frame at the point where it will come in contact with the ground stop post.. **Do not** tighten it completely at this time. You must slide the closed position stop plate toward the *ground stop* until they touch (*Illustration C*). Once you have moved the stop plate to the correct position, tighten its hardware completely.

NOTE: For a push-to-open installation (gate opens *out* from the property) attach the closed position stop plate to the **outside** of the gate.

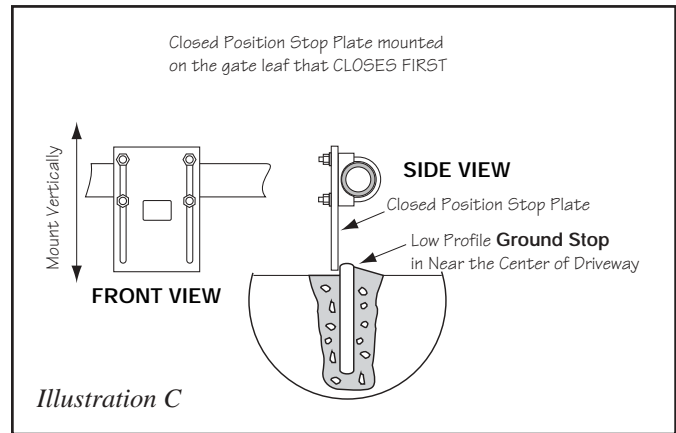

At this stage of the installation, the openers should be installed on the gate leaves and the open and closed position stops should be in place.

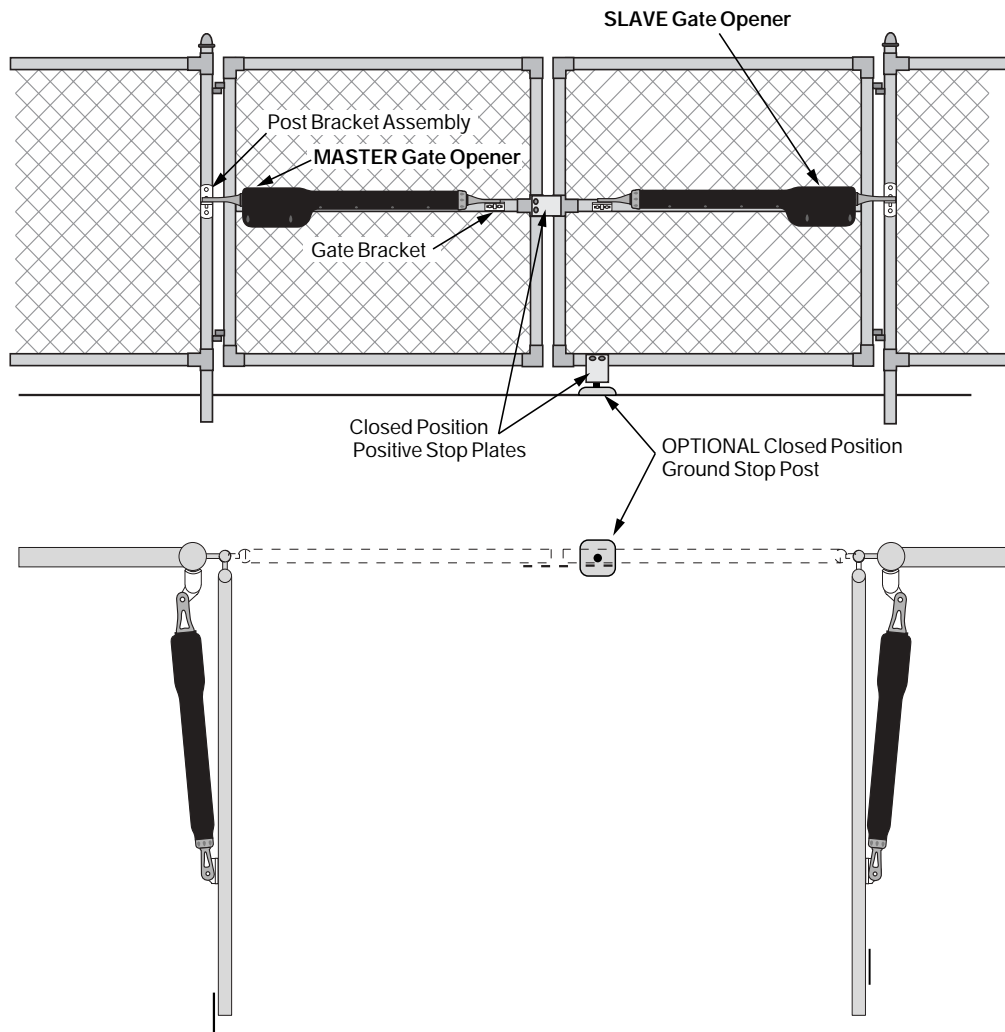

Mounting the Control Box

Step 1

Mount the control box using the screws (*provided*) or another secure mounting method. The control box must be mounted at least **3 feet above the ground** to protect it from rain splash, snow, etc., and at least **3 feet from an AC power source to prevent electrical interference.**

NOTE: The battery that came with your Mighty Mule®, **MUST** be placed in the top (horizontal) battery slot with the terminals on the **RIGHT**. The extra (vertical) battery slot is for an optional second battery. An optional second battery can be used for solar and/or high traffic applications, if needed..

Use mounting holes and screws provided to mount control box to a secure surface.

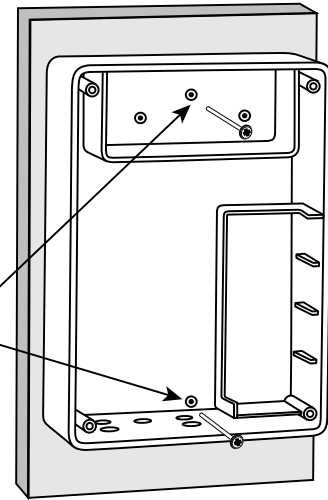

Step 2

Make sure the control box power switch is in the **OFF** position. The ON/OFF Switch is located on the bottom of the control box. Remove the control box cover and slide the battery into position with its terminals to the **RIGHT** (see illustration). Connect the **BLACK** battery wire to the **NEGATIVE (-)** battery terminal. Connect the **RED** battery wire to the **POSITIVE (+)** terminal. *Pay close attention to the color of the wires. If the wires are connected incorrectly, the control board will be damaged. NEVER insert the battery with the terminals to the left.*

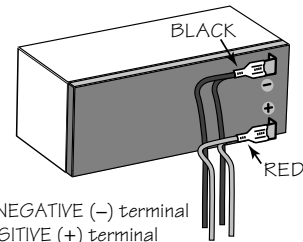

BLACK wire to NEGATIVE (-) terminal
RED wire to POSITIVE (+) terminal

Step 3

Strip approximately $\frac{3}{16}$ " of insulation from each wire of the power cable. Twist each exposed wire tightly (there are seven [7] wires inside the power cable sheath). Loosen sealing nut on strain relief hub at bottom of control box. Insert power cable into control box through strain relief. Thread approximately 6" of the power cable into the control box and retighten sealing nut until the power cable locks into place.

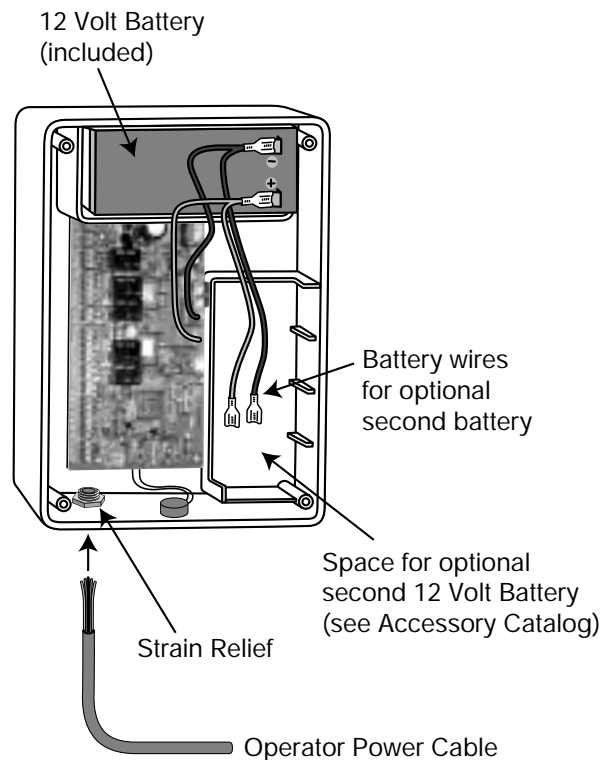
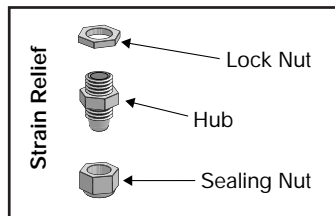

Connecting Opener Power Cables

MASTER Operator

Step 4

Insert the stripped power cable wires into the appropriate terminals on the **MASTER** operator terminal block. The green wire should be inserted into the **GRN** terminal, the blue wire into **BLU**, the orange wire into **ORG**, black wire into **BLK**, and the red wire into the **RED** terminal.

Tighten the set screws against the end of the wires. A dab of petroleum jelly on each terminal will help prevent corrosion.

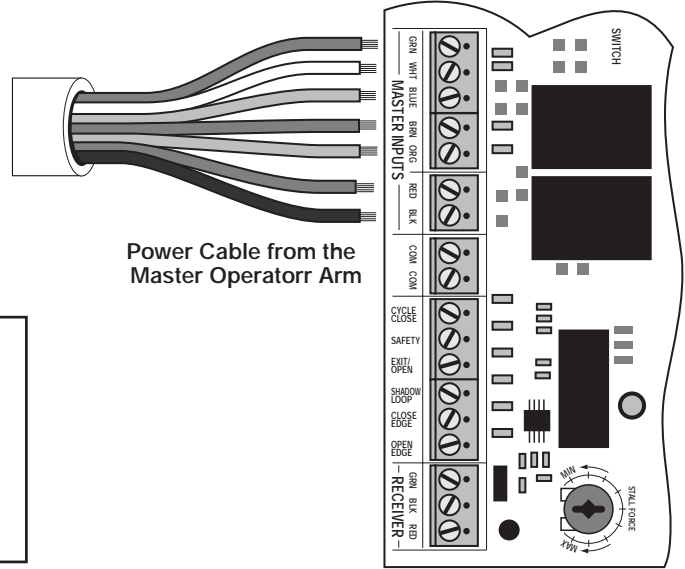
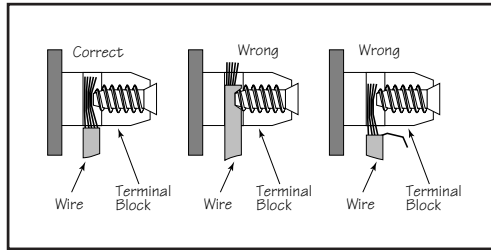

SLAVE Operator

Step 5

Review the **Installation Overview** illustration on *page 11* before proceeding.

Cut a slot into the driveway to accommodate PVC conduit (*not provided*). The buried conduit will protect the 40 foot power cable from automobile tires, lawn mower blades, weed eaters, and grazing animals. Pull the 40 foot second opener power cable through the conduit and secure them into the slot in the driveway.

Step 6

Strip approximately $\frac{3}{16}$ " of insulation from each wire of the **40 foot power cable**. Twist each exposed wire tightly. Insert the second opener power cable upward through the **right strain relief** (if necessary, loosen the sealing nut). Thread approximately 4" of wire into the control box. Retighten strain relief (on the **black sheath** of the power cable) until the power cable locks into place.

Insert the stripped wires of the power cable into the appropriate terminals on the **SLAVE** operator terminal block. The green wire should be inserted into the **GRN** terminal, the blue wire into **BLU**, the orange wire into **ORG**, black wire into **BLK**, and the red wire into the **RED** terminal.

Tighten the set screws against the end of the wires.

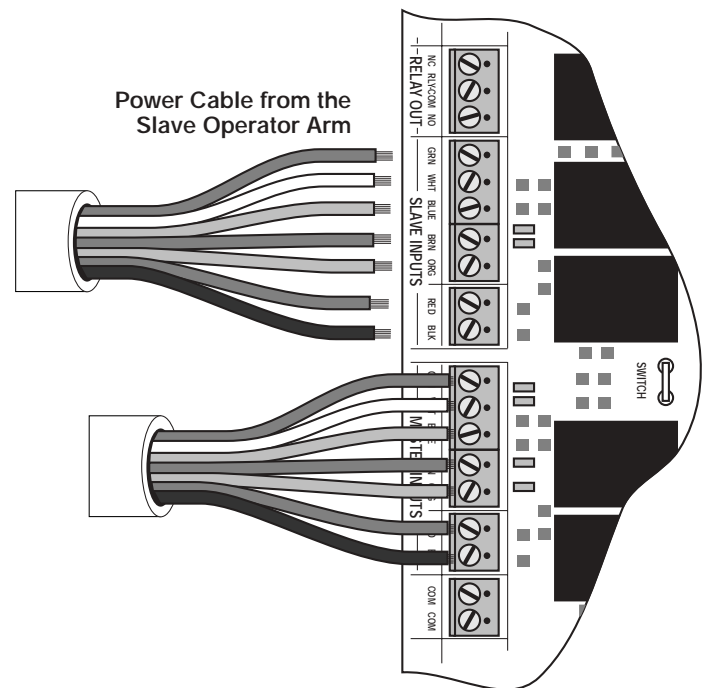

Powering the System

Installation of the Transformer

IMPORTANT:

- The transformer is designed and intended for indoor use. If the transformer can be plugged only into an outside electrical outlet, a weatherproof cover or housing (available at local electrical supply stores) **must** be used.
- All low voltage wire used with the Mighty Mule® Gate Opener must be 16 gauge dual conductor, multi-stranded, direct burial wire (see page 22 and the *Accessory Catalog*). **Do not run more than 1000 feet of wire.**
- If your gate is more than 1000 ft. from an ac power source, you will need to use at least one 5 watt Solar Panel to charge the battery (see *Accessory Catalog*). Refer to the **Solar Panels and Gate Activity** chart below.

OPTIONAL Solar Panels and Gate Activity

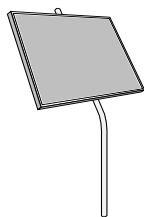

The table and map illustrate the maximum number of gate cycles to expect per day in a particular area when using from 10 to 30 watts of solar charging power. (see *Accessory*

Catalog). The figures shown are for winter (minimum sunlight) and do not account for the use of any accessory items. *Accessories connected to your system will draw additional power from the battery.*

NOTE: A maximum of 30 watts of solar charging power can be connected to the Mighty Mule® Gate Opener. Consult *Solar Panel Installation Instructions* for further information.

Winter Ratings	Zone 1	Zone 2	Zone 3
12 v dual gate (10 watts) solar charger	4	8	13
12 v dual gate (15 watts) solar charger	7	13	20
12 v dual gate (20 watts) solar charger	10	18	27
12 v dual gate (25 watts) solar charger	13	23	34
12 v dual gate (30 watts) solar charger	16	28	41

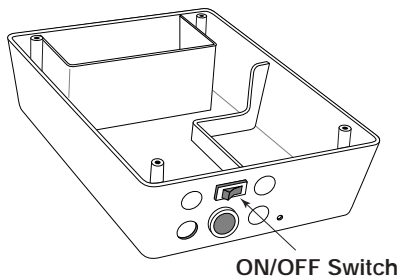

Step 1

Make sure the power switch is **OFF** before proceeding to the next step.

Step 2

Select the electrical outlet into which you will plug the transformer. Measure the distance from this outlet to the control box following the path where the wire will be laid. After you have measured how much wire is needed, cut the wire to the appropriate length.

IMPORTANT INFORMATION ABOUT LOW VOLTAGE WIRE

The only wire acceptable for use with GTO products is 16 gauge multi-stranded, low voltage, PVC sheathed wire. This particular gauge enables the transformer to provide an adequate charge through the control board to the battery at distances up to 1000 ft.

DO NOT use telephone wire or solid core wire. Unlike multi-stranded wire, these types of wire are inadequate for use with your gate opener system. Telephone wire and solid core wire do not deliver enough voltage for your gate opener to function and will cause the system to go into a condition known as "low voltage lockout."

NEVER splice wires together. Splicing permits corrosion and seriously degrades the wire's ability to carry an adequate current.

Step 3

Lay the measured length of low voltage wire in a trench following a path from the selected electrical outlet to the control box. Wires coming up from the ground should be run through PVC conduit to protect them from lawn mower blades, weed eaters, and grazing animals. Be sure to bury the wire laid in the trench.

Step 4

Feed the low voltage wires upward through the strain relief opening on the lower left of the control box. Pull 6" to 8" of wire into the control box and tighten the strain relief screw to secure the wires.

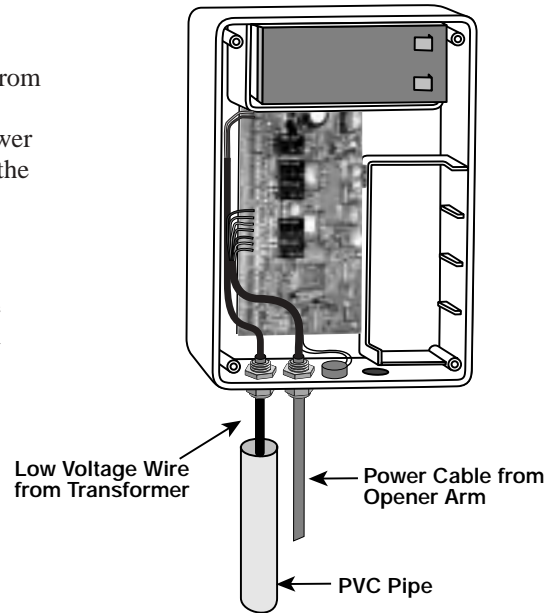

⚠ WARNING! DO NOT PLUG THE TRANSFORMER INTO AN OUTLET DURING THIS STEP! THE TRANSFORMER MUST ONLY BE PLUGGED INTO AN OUTLET DURING STEP 7!

Step 5

Strip $\frac{3}{16}$ " off the ends of the low voltage wire and twist tightly. Attach these ends to the **18VAC** terminals located on the **POWER IN** terminal block (see illustration at right). **Be certain not to let the exposed wires touch each other!**

Insert one transformer wire into an **18VAC** terminal. Insert the other transformer wire into the remaining **18VAC** terminal. The transformer wires can be connected to the **18VAC** terminals regardless of color.

Tighten set screws against exposed end of wires. A dab of household petroleum jelly on each terminal will help prevent corrosion.

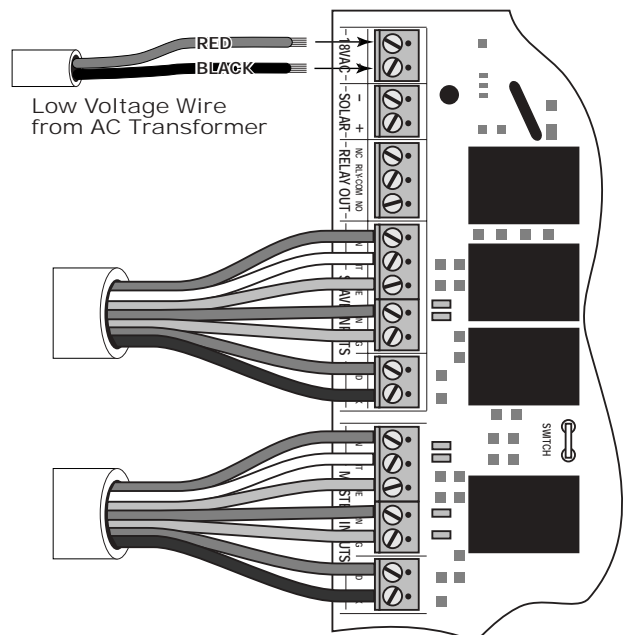

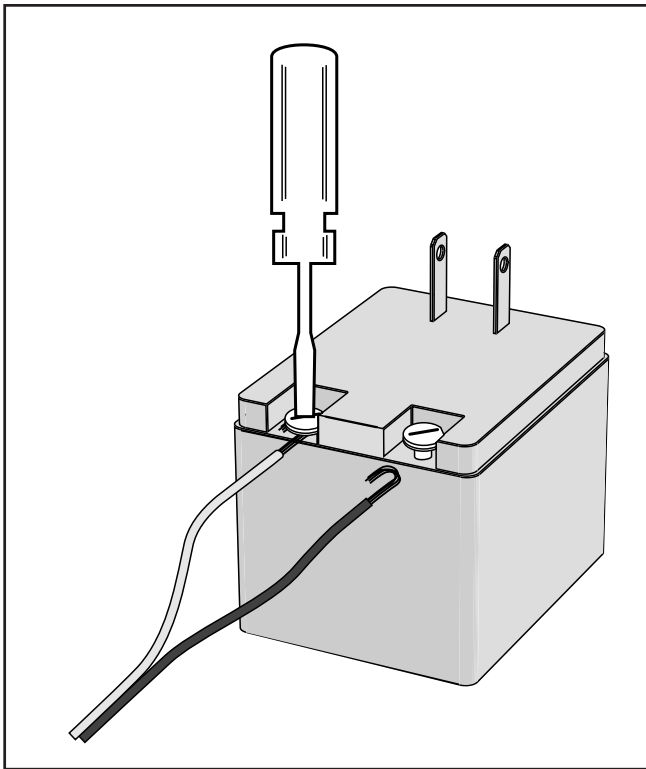

Step 6

Strip $\frac{1}{2}$ " of insulation from the ends of the low voltage wire. Attach these stripped ends to the transformer terminals.

A dab of household petroleum jelly on each terminal will help prevent corrosion.

Make sure the exposed wires do not touch each other!

Step 7

Plug the transformer into the electrical outlet.
(Use of a surge protector with the transformer is strongly recommended.)

HINT: Keep a few mothballs in the control box to discourage insects from entering it and damaging the control board.

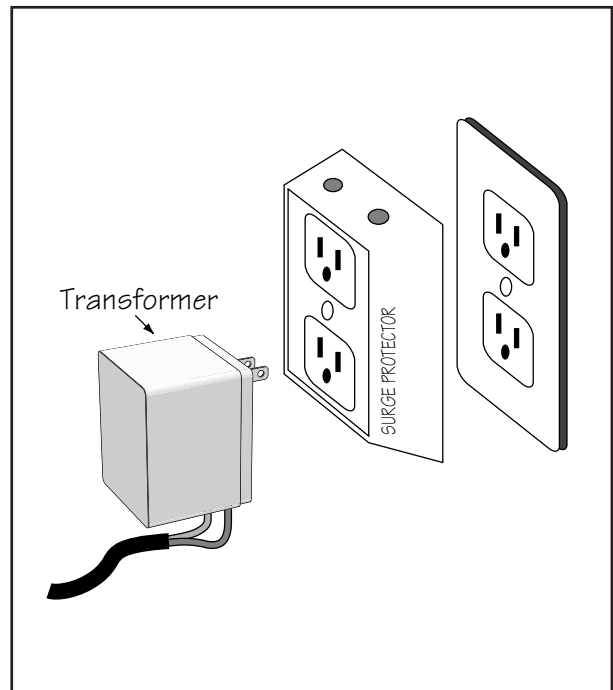

CONTROL BOARD SETTINGS

DIP Switches

NOTE: Leave DIP Switch #3 in the OFF position until installation is complete, to prevent gate from automatically closing during installation.

Main DIP Switch Settings (MODES)

DIP Switch #1 - Soft Start/Stop

The Soft Start/Stop feature slowly starts the gate as it begins to open and slows the gate as it comes to the closed position. This saves wear and tear on the gate and gate opener system.

DIP Switch #2 - Warning Buzzer

The Warning Buzzer alerts you when the gate opener is beginning to either open or close the gate. It sounds for the first 2 seconds in each direction. It also sounds a warning when the gate obstructs two times in one cycle. Switching this to OFF only disables the open and close warning not the obstruction warning.

DIP Switch #3 - Auto-Close

With the Auto-Close switch in the OFF position the gate will remain open until it receives another signal from an activation device such as a transmitter, keypad, or push button control. With the Auto-Close switch in the ON position the gate opener will automatically close the gate, if the gate is in its open limit position. The time the gate will remain open is determined using DIP Switches #6 and #7.

DIP Switch #4 - Push/Pull-to-Open

If your gate opens into the property the DIP Switch is set to OFF (factory). If your gate opens out from the property the DIP Switch must be set to the ON position. **NOTE:** if you have a Push-to-Open gate application you will need a Push-to-Open bracket (see Push-to-Open Instructions on page 30).

DIP Switch #5 - B2/D1 Mode

This DIP Switch must remain in the OFF position unless the gate opener is going to be used by a guard or gate attendant, who can only open the gate when constant pressure is applied to a push button control device.

DIP Switches #6 and #7

The combination of these two switches determines the amount of time the gate will remain open when DIP Switch #3 is set in the ON position.

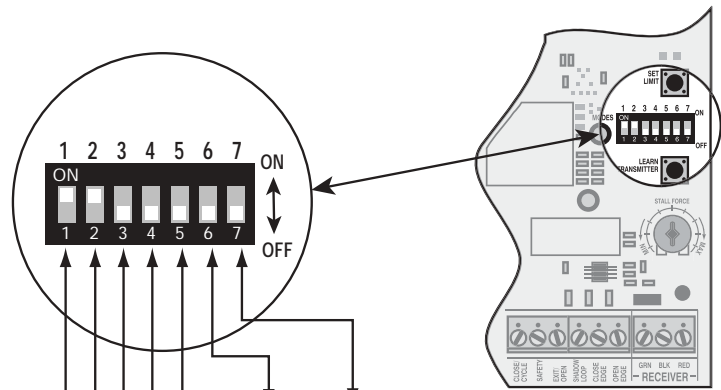

DIP#6	DIP#7	Delay Time for Auto-Close
ON	ON	15 seconds
ON	OFF	30 seconds
OFF	ON	60 seconds
OFF*	OFF*	120 seconds (factory preset)

DIP#5

ON ___ D1 mode, constant pressure to operate gate.
OFF* ___ B2 mode, momentary contact to operate gate.

DIP#4

ON ___ Push-to-open operation.
OFF* ___ Pull-to-open operation.

DIP#3

ON ___ Auto-close enabled.
OFF* ___ Auto-close disabled.

DIP#2

ON* ___ Buzzer warning enabled.
OFF ___ Buzzer warning disabled

DIP#1

ON* ___ Soft start enabled.
OFF ___ Soft start disabled.

* Factory preset.

Dual Gate DIP Switch Settings (DUAL MODES)

DIP Switches #1 and #2 (Factory Set OFF/OFF)

The combination of DIP Switches #1 and #2 will determine the sequence dual gates will open and close.

DIP Switch #3 - Additional Delay (Factory Set OFF)

To add 4 seconds to the standard 4 seconds, a total of 8 seconds delay, sequence delay switch to ON.

DIP Switch #4 - Used to set MASTER and SLAVE gate closed position limits (next section).

#4 ON = when setting closed limit for SLAVE gate.

#4 OFF = when setting closed limit for MASTER gate.

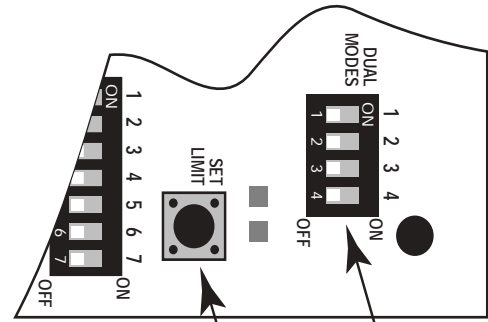

#1 OFF & #2 OFF

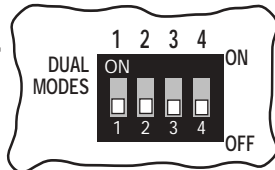

Factory setting.
Single Arm (Master Only) operation.

Set Limit Button

Dual Mode DIP Switches

#1 ON, #2 OFF
and #3 OFF

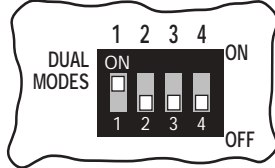

MASTER gate starts to open 2 seconds before SLAVE gate / SLAVE gate starts to close 4 seconds before MASTER gate.

#1 ON, #2 OFF
and #3 ON *

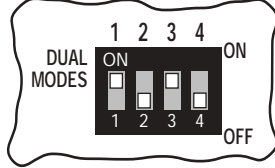

MASTER gate starts to open 2 seconds before SLAVE gate / SLAVE gate starts to close 8 seconds before MASTER gate.

#1 OFF, #2 ON
and #3 OFF

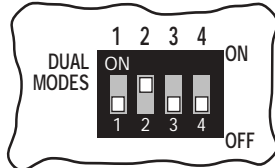

MASTER and SLAVE gates open simultaneously / SLAVE gate starts to close 4 seconds before MASTER gate.

#1 OFF, #2 ON
and #3 ON

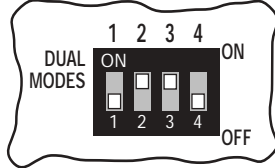

MASTER and SLAVE gates open simultaneously / SLAVE gate starts to close 8 seconds before MASTER gate.

* REQUIRED SETTING for use with an Automatic Gate Lock accessory.

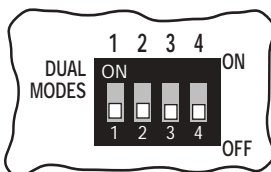

#4 OFF to set or CLEAR
MASTER Position Limit

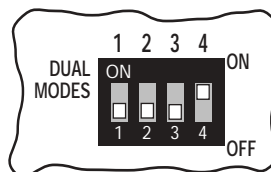

#4 ON to set or CLEAR
SLAVE Position Limit

Setting the Closed Position Limits

TURN CONTROL BOX ON

Your Mighty Mule® has two Limit Settings

1) **OPEN Limit setting:** (Gate in the OPEN POSITION / FACTORY SET NOT ADJUSTABLE) The open limit setting is the fully open position.

2) **CLOSED Limit setting:** (Gate in the CLOSED POSITION) To achieve optimum closed position, you are required to complete the following SEVEN STEPS:

Step 1

Confirm that the power switch is in the ON position, and the gates are in the OPEN POSITIONS.

Step 2

Activate your openers by pressing the entry transmitter button. Your gates should now be moving from the fully open positions toward their closing position. Prepare to STOP gate that reaches the desired closed position first by pressing the entry transmitter button again. This step may be repeated until desired close position is achieved. Once the desired CLOSED position has been achieved, proceed to step 3.

Step 3

With the gate that closed first in the desired closed position, program the closed limit setting by setting the number 4 DIP switch on the DUAL MODES switches to the OFF position (if the MASTER gate closed first) or the ON position (if the SLAVE gate closed first) then PRESS & HOLD the "SET LIMIT" button on the control board for 5 seconds.

Step 4

Press the transmitter button and allow the gates to return to the fully open position. YOUR FIRST GATE'S CLOSED POSITION LIMIT IS NOW PROGRAMMED.

Step 5

Activate your openers again by pressing the entry transmitter button. Your gates should now be moving from the fully open positions toward their closing position. The first gate will stop at the spot you just programmed and the second gate will continue to close until you press the transmitter button again. The optimum CLOSED POSITION for the second gate is when it closes firmly, without excess tension, against the first gate. This step may be repeated until desired close position is achieved. Once the desired CLOSED position has been achieved, proceed to step 6.

Step 6

With the second gate in the desired closed position. Program the closed limit setting by setting the number 4 DIP switch on the DUAL MODES switches to the ON position (if the MASTER gate closed first) or the OFF position (if the SLAVE gate closed first) then PRESS & HOLD the "SET LIMIT" button on the control board for 5 seconds.

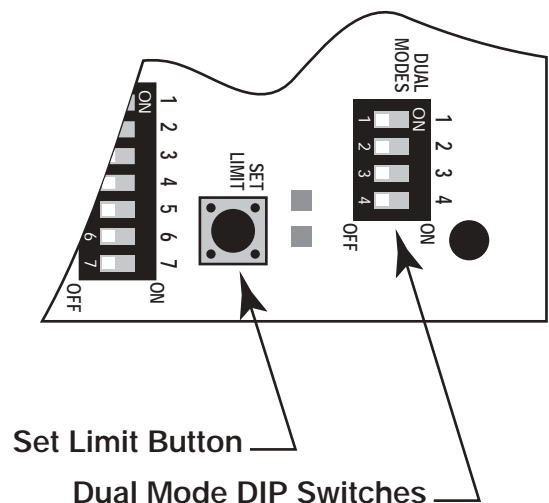

Step 7

Press the transmitter button and allow the gates to return to the fully open position. BOTH YOUR MASTER AND SLAVE GATE'S CLOSED POSITION LIMITS ARE NOW PROGRAMMED.

TESTING YOUR CLOSED LIMIT SETTING:

Press your entry transmitter and allow your gates to close. If CLOSED positions are not correct or need to be changed, you will need to CLEAR your CLOSED LIMIT settings and follow Steps 1-7 again.

CLEARING PROGRAMMED CLOSED LIMIT SETTING:

If you make a mistake and set the limit at the wrong position – press your transmitter to return the gates to their fully opened positions, then press and hold the "SET LIMIT" button for 10 seconds. This will clear the memory for the closed limit positions. Follow Steps 1-7 again.

Setting Your Personal Transmitter Code

All GTO transmitters are set to a standard code at the factory and are ready to operate your Mighty Mule® Gate Opener®. For your safety and security, however, we **strongly recommend** that you replace the factory setting with your own personal code. Follow the directions below:

1. Remove the Transmitter Cover

Grasp the sides of the access cover and slide it away from the transmitter button (see illustration). When the access cover is removed, the battery and the DIP switches will be exposed. To set a new code, use a small screwdriver to move the switches.

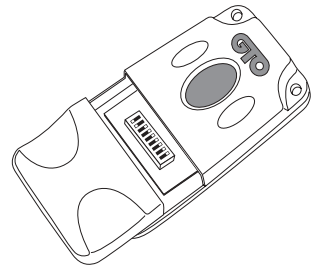

2. Set the transmitter DIP Switches

There are nine (9) transmitter DIP switches; each can be placed in three different positions (+, 0, -). **DO NOT** set all the switches in the same position, such as all +, all 0, or all -. Once the DIP switches have been set to a personal code, replace and close the access cover.

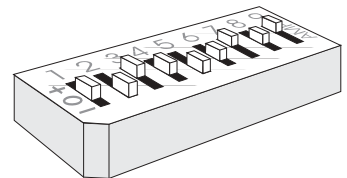

WARNING: No other adjustments should be made inside the transmitter.

3. "Teach" the New Code to Control Board Memory

- Press and hold transmitter button.
- Press and hold the **LEARN TRANSMITTER** button on the control board for 5 seconds.
- Release **LEARN TRANSMITTER** button.
- Release transmitter button. The new code is stored in control board memory.

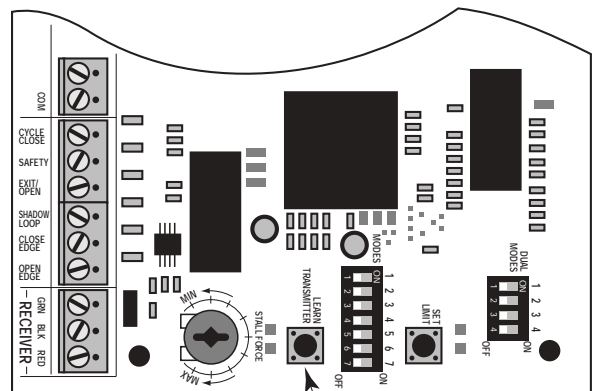

Learn Transmitter Button

Obstruction Sensitivity Potentiometer

IMPORTANT: For safety reasons the obstruction setting or **Stall Force** on the Mighty Mule® control board comes from the factory set at **MIN** (minimum). In many gate installations this setting will need to be adjusted to overcome the weight and size of the gates.

The **Stall Force** potentiometer on the control board operates like a volume control on a radio. It controls the obstruction sensitivity (or the amount of force the opener will apply to an obstruction) before it automatically stops and reverses direction for approximately two (2) seconds.

Use a small slotted screwdriver to turn the arrow in the center of the potentiometer. Adjust the sensitivity from the **MINIMUM** position where the gate operates without obstructing from its own weight or the wind conditions in your area.

NOTE: You may need to increase the stall force in cold weather due to increased resistance from gate hinges.

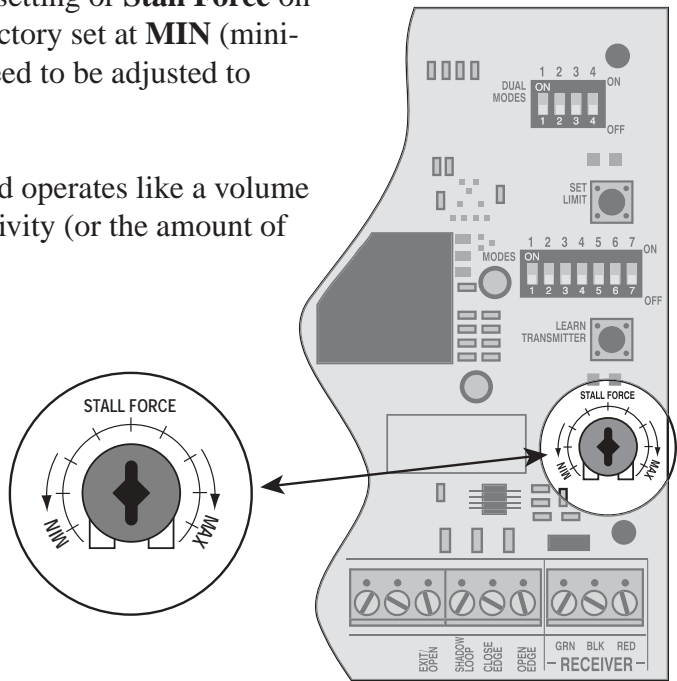

ALWAYS KEEP SAFETY AT THE TOP OF YOUR LIST WHEN ADJUSTING OR SERVICING YOUR AUTOMATIC GATE OPENER!

Installing the Receiver

Use the transmitter to check the range of the receiver *before permanently mounting it.*

Consider the following when mounting the receiver:

- Standard receiver cable length is 10 feet (receivers with a longer cable are available as special order items; *call the GTO Sales Department*). NEVER splice receiver cable!
- **Run the cable through PVC conduit to protect it from damage.**
- DO NOT run cable through metal conduit because the receiver signal range will be decreased.
- DO NOT run cable in conduit containing ac wiring.
- DO NOT mount receiver on a metal fence or post; doing so will decrease signal range.
- The receiver range can vary from 50 to 100 feet depending upon weather, topography, and external interference.
- **DO NOT mount upside down.**

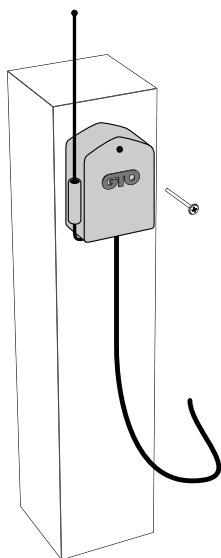

FCC Regulation

This device complies with FCC rules Part 15. Operation is subject to the following conditions:

1. This device may not cause harmful interference.
2. This device must accept an interference that may cause undesired operation.

Transmitter distance may vary due to circumstances beyond our control. **NOTE: The manufacturer is not responsible for any radio or TV interference caused by unauthorized modifications to this equipment. Such modifications could void the user's authority to operate the equipment.**

Connecting Additional Safety Devices

Although GTO strongly recommends the use of additional safety devices, we do not endorse any specific brand names. Only use products that are certified and listed to be in compliance with any applicable UL standards (United Laboratories) and national and regional safety codes.

Call GTO Sales at 1-800-543-4283 for information on compatible products for your specific application.

The Mighty Mule® 502 will ONLY accept accessory devices with normally open dry contact output.

Contact Sensors (safety edges)

If not installing a contact sensor skip to next section.

PLEASE NOTE: Contact sensors are not *included with* the Mighty Mule® 502.

The Mighty Mule® 502 is equipped with built-in obstruction sensitivity. The opener is designed to stop and reverse the gate within 2 seconds when it comes in contact with an obstruction. However, obstruction sensitivity, although functioning properly, *may not be sensitive enough to prevent bodily injury in some circumstances*. To augment your protection against entrapment, **GTO recommends using some form of additional safety device**. When installed, contact sensors must be mounted in compliance with UL 325, Underwriters Laboratories safety standard for gate openers. Review page 5 for information about mounting requirements for safety edges ("contact sensors").

Refer to the sensor manufacturer's instructions for information about installing these devices on a vehicular gate.

⚠ Make sure the power switch to the opener is turned off before connecting safety device wiring to the terminal blocks. Unplugging the transformer does not turn power to the opener OFF.

Contact Sensor Input Connection:

Connect one of the OPEN EDGE contact sensor wires to the **COMMON (COM)** terminal and the other to the **OPEN EDGE** terminal on the Mighty Mule® 502 control board.

Connect one of the CLOSE EDGE contact sensor wires to the **COMMON (COM)** terminal and the other to the **CLOSE EDGE** terminal on the Mighty Mule® 502 control board.

Activation of a contact sensor while the gate is in motion will cause the gate to stop and reverse within two (2) seconds.

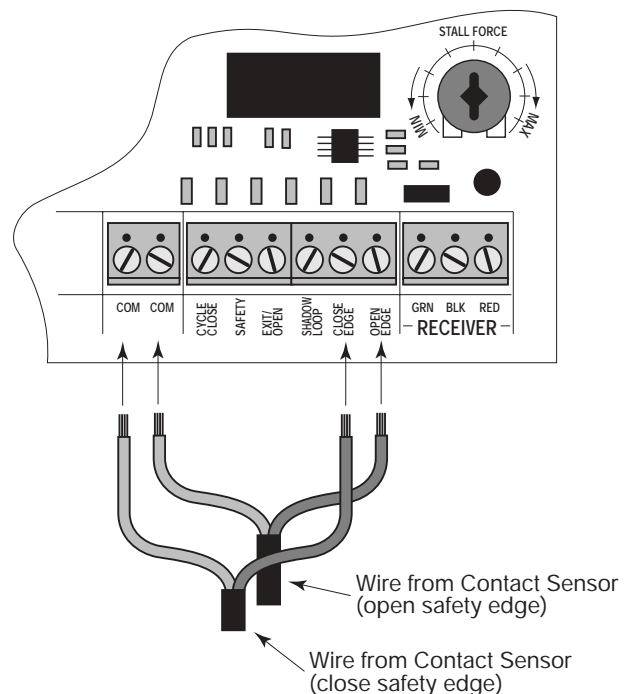

Non-Contact Sensors (photo beams)

If not installing a non-contact sensor skip to next section.

PLEASE NOTE: Non-contact sensors are not *included with* the Mighty Mule® 502.

The Mighty Mule® 502 can also accept "Safety" input from normally open "dry-contact" output devices such as safety beams connected to the SAFETY input terminal.

Refer to the sensor manufacturer's instructions for information about installing these devices on a vehicular gate.

⚠ Make sure the power to the opener is turned off before connecting safety device wiring to the terminal blocks. Unplugging the transformer does not turn power to the opener OFF.

Non-Contact Sensor Connection:

Connect one of the non-contact sensor dry contact output wires to the **COMMON (COM)** terminal and the other to the **SAFETY** terminal on the Mighty Mule® 502 control board.

This input is ONLY monitored when the gate is closing. Activating the non-contact sensor (obstructing the safety beam path) will cause the gate to reverse to the fully open position.

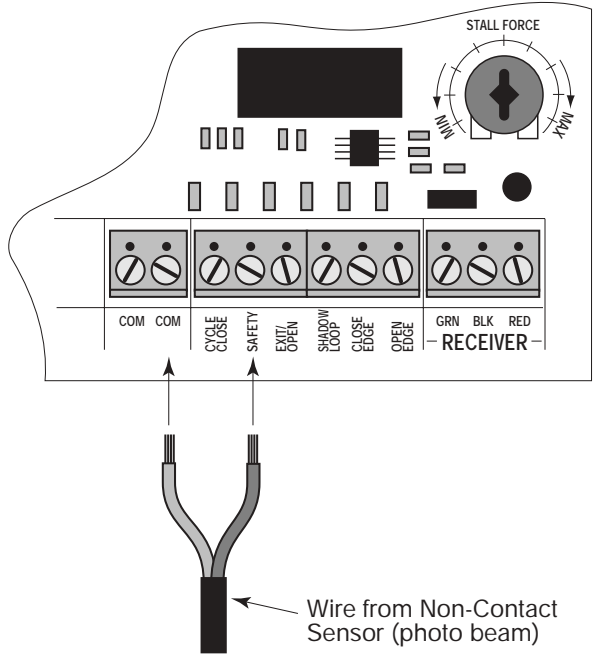

Shadow Loop

If not installing a shadow loop skip to next section.

PLEASE NOTE: Non-contact sensors are not *included with* the Mighty Mule® 502.

Refer to the sensor manufacturer's instructions for information about installing these devices on a vehicular gate.

⚠ Make sure the power to the opener is turned off before connecting safety device wiring to the terminal blocks. Unplugging the transformer does not turn power to the opener OFF.

Shadow Loop Connection:

Connect one of the shadow loop wires to the **COMMON (COM)** terminal and the other to the **SHADOW LOOP** terminal on the Mighty Mule® 502 control board.

The **SHADOW LOOP** is a detector located with the moving path of the gate to prevent the gate from closing when a vehicle is in the path.

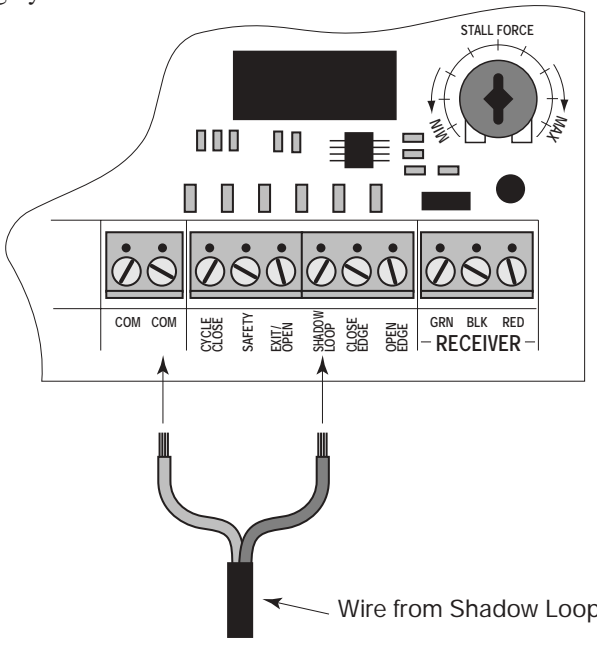

Connecting Accessories

If not connecting accessories skip to next section.

The Mighty Mule® 502 can accept NORMALLY OPEN CONTACT accessories, such as; Push Button Entry Devices and Key Pads.

Refer to the sensor manufacturer's instructions for information about installing these devices on a vehicular gate.

⚠ Make sure the power to the opener is turned off before connecting safety device wiring to the terminal blocks. Unplugging the transformer does not turn power to the opener OFF.

Accessory Input Connection:

Connect one of the accessory wires to the **COMMON (COM)** terminal and the other to the **CYCLE CLOSE** terminal on the Mighty Mule® 502 control board.

Each activation of the accessory will cause the gate to cycle as follows:

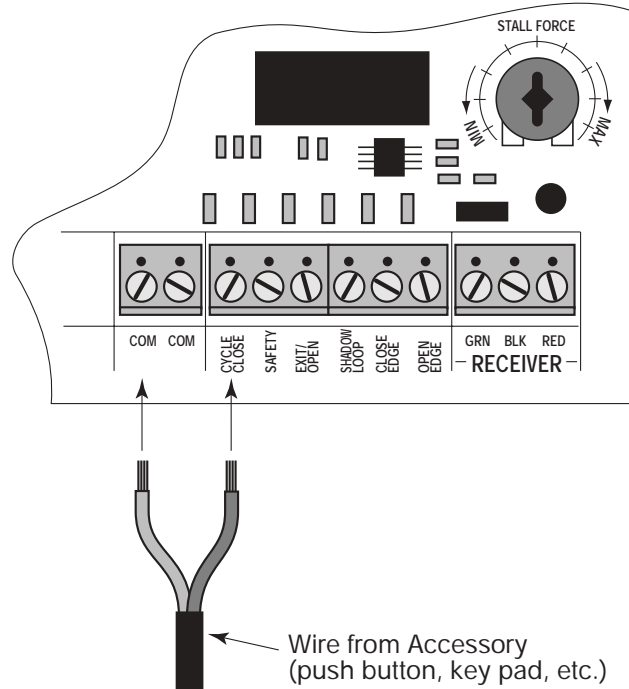
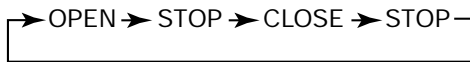

Push to Open Installation

Determining The Mounting Position of The Post Bracket Assembly

⚠ Swinging gates shall not open into public access areas!

A "Push-to-Open" gate opens *out* from the property.

A Push-to-Open Bracket is required for this type of installation (see *Accessory Catalog*). If you have a pull-to-open gate (gate opens *into* the property), return to page 13; step 3.

In a PUSH-TO-OPEN installation the openers are installed while the gates are in the **closed** position.

Step 1

With the gates **closed**, adjust the post bracket assembly and the gate bracket until the opener is level. While holding the opener level, use C-clamps to temporarily keep the post bracket assembly and gate bracket in their respective positions on the fence post and gate.

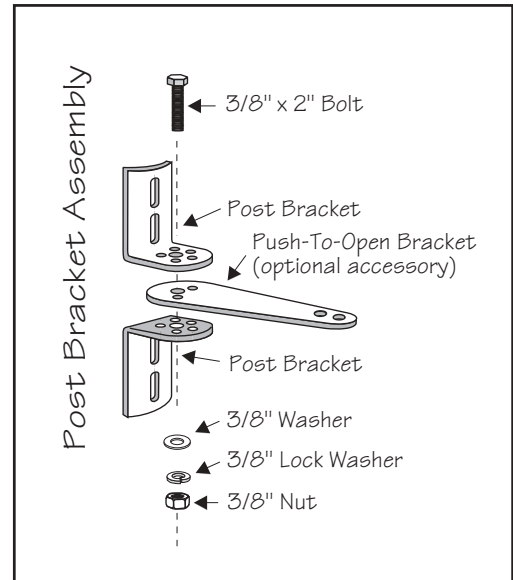

IMPORTANT: While determining the mounting point for the post pivot bracket assembly be sure that the position allows for maximum clearance between the gate and the opener in both the open and closed positions, as shown in the diagrams below. This clearance will give the opener the most efficient leverage point for opening and closing the gate and more importantly provides the least possible pinch area.

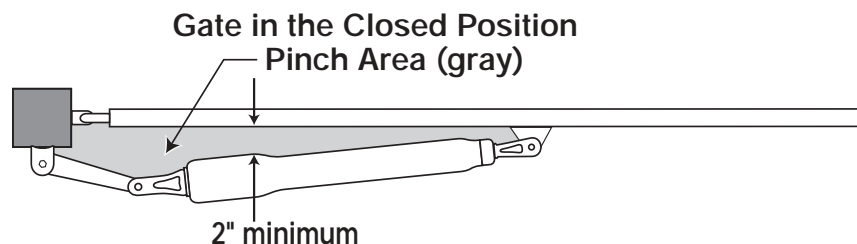
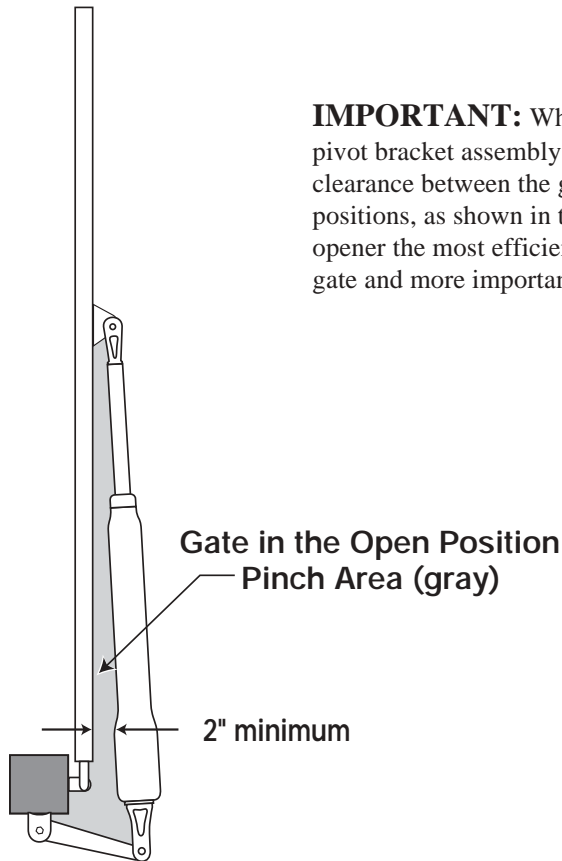

Step 2

After verifying that you have the best position for the post pivot bracket, insert the $\frac{5}{16}$ " x $1\frac{3}{4}$ " bolt through the aligned holes of the post bracket and post pivot bracket and fasten it with the $\frac{5}{16}$ " washer and nut.

IMPORTANT: If you loosened the clamp on the post bracket to achieve the optimum position, tighten it in its new position and recheck the gate bracket with the gate in the open position (move the gate bracket and re-clamp it if necessary).

Step 3

With the gate in the **fully closed position** and the opener retracted, swing the opener to the gate. Mark reference points for bolt holes on gate cross member through middle of gate bracket slots. The opener must be level. (Some vertical adjustment is possible by sliding the post bracket assembly up and down.) Drill $\frac{3}{8}$ " holes into the gate cross member as marked. Fasten gate bracket to cross member using (2) $\frac{3}{8}$ " x 3" bolts, washers, lock washers, and nuts. Attach the opener to the post bracket assembly and gate bracket using clevis pins, bushings, and hairpins clips.

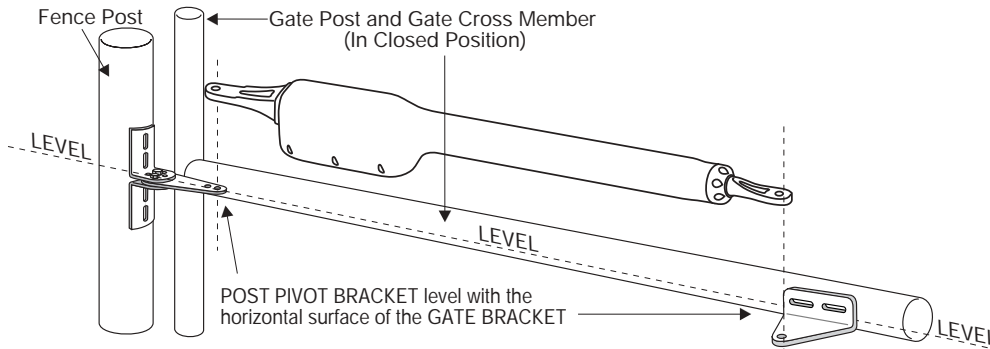

Step 4

Make sure the control box power switch is **OFF**. Use a small screwdriver to move the **Number 4** DIP switch from the factory setting (OFF / Pull-To-Open) to **ON for Push-To-Open**. Turn power switch **ON**. The control board is now configured to *push* the gate open.

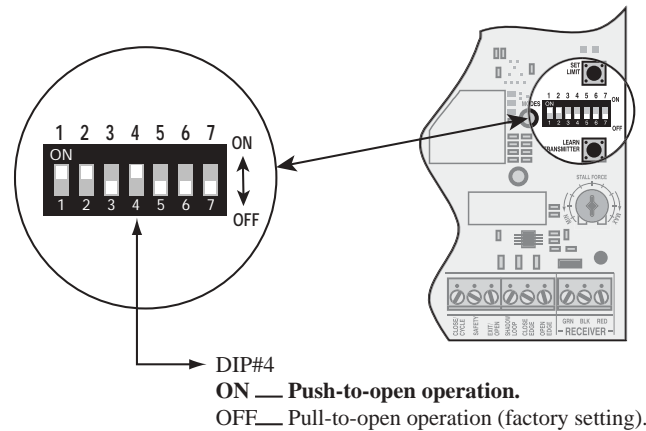

Step 5

Install the second gate opener on the other gate in the same manner. Then refer to the **CONTROL BOARD SETTINGS** on page 25 for gate sequencing and other programming steps before proceeding.

Setting the Open Position Limit

Step 1

Confirm that the power switch is in the ON position, and the gates are in the CLOSED POSITIONS.

Step 2

Activate your openers by pressing the entry transmitter button. Your gates should now be moving from the closed positions toward their open position. Prepare to **STOP** gates by pressing the entry transmitter button again when the first gate reaches the desired open position. This step may be repeated until desired open position is achieved. Once the desired **OPEN** position has been achieved, proceed to step 3.

Step 3

With the first gate in the desired open position. Program the open limit setting by setting the number 4 DIP switch on the DUAL MODES switches to the OFF position (if the MASTER gate opened first) or the ON position (if the SLAVE gate opened first) then PRESS & HOLD the "SET LIMIT" button on the control board for 5 seconds.

Step 4

Press the transmitter button and allow the gates to return to the closed position. YOUR FIRST GATE'S OPEN POSITION LIMIT IS NOW PROGRAMMED.

Step 5

Activate your openers again by pressing the entry transmitter button. Your gates should now be moving from the closed positions toward their open positions. The first gate will stop at the spot you just programmed and the second gate will continue to open until you press the transmitter button again. Press the transmitter button when the second gate reaches the desired open position. This step may be repeated until desired open position is achieved. Once the desired OPEN position has been achieved, proceed to step 6.

Step 6

With the second gate in the desired open position. Program the open limit setting by setting the number 4 DIP switch on the DUAL MODES switches to the ON position (if the MASTER gate opened first) or the OFF position (if the SLAVE gate opened first) then PRESS & HOLD the "SET LIMIT" button on the control board for 5 seconds.

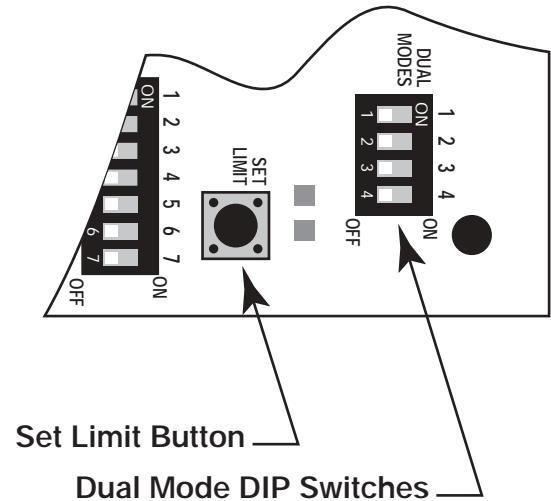

Step 7

Press the transmitter button and allow the gates to return to the closed position. BOTH YOUR MASTER AND SLAVE GATE'S OPEN POSITION LIMITS ARE NOW PROGRAMMED.

TESTING YOUR OPEN LIMIT SETTING:

Press your entry transmitter and allow your gates to open. If OPEN positions are not correct or need to be changed, you will need to CLEAR your OPEN LIMIT settings and follow steps one (1) to seven (7) again.

CLEARING THE PROGRAMMED OPEN LIMIT SETTING:

If you make a mistake and set the limit at the wrong position – press your transmitter to return the gates to their closed positions, then press and hold the "SET LIMIT" button for 10 seconds. This will clear the memory for the open limit positions. Follow steps one (1) to seven (7) again.

Maintenance & Troubleshooting Guide

If your gate opener does not function properly after it is installed, use this guide before calling the GTO Service Department.

- On all gates weighing 250 lb. or more, routinely grease the ball bearing hinges at least 4 times a year; more frequently if the gates are near a coastal area.
- Keeping a few mothballs in the control box will discourage insects from entering it and damaging the control board.
- Clean the push-pull tube with a soft, dry cloth and apply silicone spray to it at least once per month.
- While oxidation is a normal part of weathering of equipment that is exposed to the elements, we recommend you apply silicone spray the front and rear mounts to minimize this effect.

If the Opener Does Not Work

Check the Green LED on the Control Board:

IF THE LED IS OFF: This condition indicates a transformer power failure.

1. Test the transformer for voltage with a voltmeter. The acceptable range can be found in the **VOLTAGE LIMITS** chart on the next page. If the transformer test shows no voltage, then test the electrical outlet for voltage. If the outlet test shows voltage, then the transformer is dead and must be replaced. Allow the new transformer 12 hours to charge the battery before using the gate opener.
2. If the transformer test shows voltage, check the **POWER IN** terminal block on the control board for voltage. If the terminal block shows no voltage, look for broken or spliced wires.

Check the Red STATUS LED on the Control Board:

IF THE LED IS ON: but the unit is not working.

1. Check the battery in your transmitter and replace with a fresh one if needed..
2. Verify that the power cable is securely connected.
3. Replace the control board fuse if it is blown (**2 5 ampere fuse only - DO NOT USE A HIGHER RATED FUSE!**).

IF THE LED IS OFF:

1. Make sure the **ON / OFF** switch at the bottom of the control box is set to **ON**.
2. Check all connections for looseness and corrosion.

If the Opener is Working

The Gate CLOSES Then Opens Again on its Own:

1. Check the position of the mounting brackets and readjust if necessary.
2. Check the gate for binding or hinge damage.

The Gate OPENS Then Closes Again on its Own:

1. Check the position of the mounting brackets and readjust if necessary.
2. Check the gate for binding or hinge damage.

VOLTAGE RATINGS

18 Vac Transformer _____	18.0 to 22.0 Vac
5 W Solar panel (single) _____ measure voltage at panel and control box.	18.0 to 22.0 Vdc 300 mA
12 V Battery _____	12.0 to 13.5 Vdc 7.0 Ah
Charging circuit _____ measure voltage with battery connected	12.0 to 14.8 Vdc

The **GTO, Inc. Technical Service Department** is open
Monday – Friday 7:30 A.M. – 5:30 P.M. (Eastern Time)

Telephone (800) 543-1236
Telephone (850) 575-4144

Fax (850) 575-8950 • Web site:
www.mightymule.com
E-Mail: techsupport@gtoinc.com

Repair Service

If your Mighty Mule® Gate Opener is not operating properly, please follow the steps below:

1. First use the procedures found in the *Maintenance & Troubleshooting Guide* (see page 35).
2. If you are unable to solve the problem, call the **GTO Service Department** at (800) 543-1236, or (850) 575-4144. Refer to the serial number (located on the control box cover) and date of purchase when calling for assistance.
3. If repair or replacement of your gate opener is necessary, the Service Department will assign a **Return Goods Authorization (RGA) number** to you for warranty repair.
4. Securely pack the component(s) authorized for return to the factory. Write the RGA number issued to you on the outside of the package in **LARGE BOLD PRINT**. Ship the package(s) freight prepaid to:
GTO, Inc., 3121 Hartsfield Road, Tallahassee, Florida, USA 32303.

NOTE: Products returned to GTO without a Return Goods Authorization (RGA) number in LARGE BOLD PRINT on the outside of the package WILL NOT be accepted. Also, items returned to GTO freight collect WILL NOT be accepted.

Column Installation Information

IF THIS OPENER WILL BE USED WITH GATES THAT ARE MOUNTED ON MASONRY, BRICK, OR ROCK (etc.) COLUMNS:

READ THE FOLLOWING CAREFULLY BEFORE PROCEEDING

- A. The simplest solution is to install the opener in a push-to-open configuration (requires Push-To-Open Bracket, see Accessory Catalog). The minimum clearance is easier to achieve and clearance is no longer a problem, since the opener will be pushing the gate away from the column instead of pulling it toward the column. It is recommended that you place a steel plate between the opener mounting brackets and masonry surface for additional strength.
- B. If a push-to-open installation is impossible due to traffic hazards, terrain, etc., another option is to re-hang the gate. You may hang it on a post, either in the center of the column or at the back corner, or move the gate to the back corner of the columns.
- C. The most difficult solution is to cut a notch in the column to accommodate the opener and power cable. This job is **NOT** for the inexperienced!

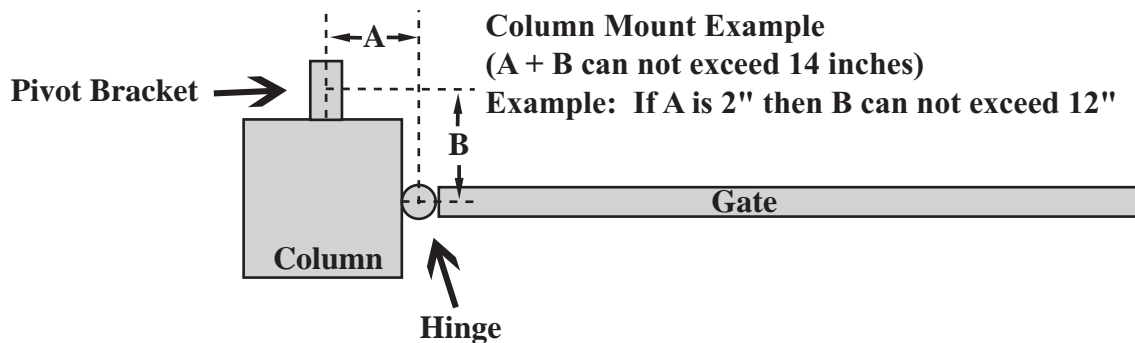



ACCESSORIES

Accessories are Available From Your Retail Store

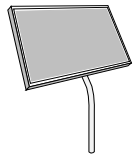

SSolar Panel (FM121) *Not Compatible with Mighty Mule® 250*

The **Solar Panel** is a 5 watt solar powered battery charger for use with the **FM500 & FM502** gate opener systems. Particularly suited for remote installations, each **Solar Panel** comes with tubular steel support, mounting clips, wire connectors, and 8 ft. of low voltage wire (see Low Voltage Wire for additional wire). The **Mighty Mule®** control board has clearly labeled terminal connections for easy installation of the **Solar Panel**. Installation in some regions of the world will require multiple solar panels for adequate charging power. Dual gates require a minimum of 10 watts of solar charging power. (10 watt solar panels are available)



Push Button (doorbell) Control (FM132)

Unlit doorbell button for remote entry or exit control. Wires directly to the control board and uses 16 gauge multi-stranded, dual conductor low voltage wire (sold separately).

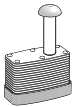

Pin Lock (FM133)

The **Pin Lock** substitutes for the clevis pin at the front end of the **Mighty Mule®** gate openers. Helps prevent theft of the opener from the gate, while allowing quick release of the opener.



Key Chain Mini Transmitter (FM134)

The **Key Chain Mini Transmitter** is a miniature version of the **Mighty Mule®** entry transmitter and has the same adjustable code settings. 12 Volt battery included.



Entry Transmitter (FM135)

The **Mighty Mule®** entry transmitter, with adjustable code settings, is standard equipment with all **Mighty Mule®** systems. 9 Volt battery included.



Digital Keypad (FM137)

The specially designed digital keypad can be easily installed as a wireless or wired keypad. It can be programmed to use up to fifteen different personal identification number (PIN) codes. Each code is face programmable with additional security features built in. Wired installations require 16 gauge, low voltage, multi-stranded, dual conductor, direct burial wire (sold separately). Requires 3 AA batteries (not included).

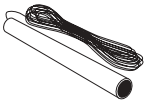

Gate Opening Sensor (FM138) *Not Compatible with Mighty Mule® 250*

The **Gate Opening Sensor** is designed for residential and agricultural applications and is compatible with most **Mighty Mule®** automatic gate opener models (see Sensor Box for model compatibility). The **Sensor** is an electromagnetic sensor, which offers 'hands free' operation of the **Mighty Mule®** Gate Opener with a 12 ft. radius of detection of vehicles in motion.

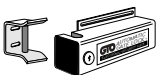

Automatic Gate Lock Pull-to-Open (FM143) *Not Compatible with Mighty Mule® 250*

A **MUST** for added security. Solenoid driven with a steel housing. Unlocks and locks automatically as gates open and close. Used with the **Mighty Mule®** system for maximum stability and security. Comes with a keyed manual release. Recommended for gates over 8 ft. long. Ideal for animal enclosures or high wind areas.

Accessories are Available From Your Retail Store (con't)



Replacement Battery (FM150) *Not Compatible with Mighty Mule® 250*

Standard 12 volt, 7.0 amp-hour, maintenance-free battery for the **Mighty Mule® FM500 & FM502** gate opener systems. This is the only battery approved for use with the **Mighty Mule® FM500 & FM502** gate opener systems. Life expectancy is 3-5 years.



Low Voltage Wire (RB509)

The 16 gauge, multi-stranded, dual conductor **Low Voltage Wire** is for connecting the AC powered transformer, or the **Solar Panel** to the control board. Also used for the connection of accessories, such as locks, keypads, push buttons and other wired control devices. This specially designed wire is UV treated, PVC coated and ready for direct burial. Available in 1000' rolls or special lengths.

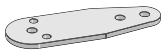

11" Push to Open Bracket (FM148) *Not Compatible with Mighty Mule® 250*

Required when **Mighty Mule® 500/502** gate opener(s) must push the gate open, such as on a sloping driveway or where space prevents gate(s) from opening inward (pulled open). Order two PTO brackets for conversion of a dual swing gate installation.



Column Mount Lock Receiver (433IH) *Not Compatible with Mighty Mule® 250*

For mounting the **Automatic Gate Lock** on brick columns, walls, or for other applications with limited space between gate and post.

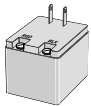

Replacement Transformer (RB570)

Standard 18 volt AC transformer for maintaining the battery included with the **Mighty Mule®** gate opener. This is the only transformer approved for use with **all UL325 Mighty Mule®** gate opener systems.

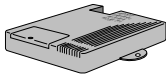

Garage Door Receiver (RB709)

The Garage Door Receiver allows you to use the same **Mighty Mule®** entry transmitter (see Dual and Triple Transmitters) to operate your gate opener and your garage door opener. Compatible with most garage door openers.

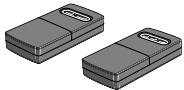

Dual & Triple Button Transmitters (RB742 & RB743)

The Dual (RB742) & Triple (RB743) Button Transmitters are for remote control of multiple separate gate openers, and/or gate opener(s) and garage door opener(s) (see Garage Door Receiver). 9 Volt battery included.

If you have a question about any special order item,
just call 1-800-543-GATE!

The contents of all material available on this installation manual are copyrighted by GTO, Inc. ("GTO"), unless otherwise indicated. All rights are reserved by GTO, and content may not be reproduced, downloaded, disseminated, published, or transferred in any form or by any means, except with the prior, written permission of GTO. Any reprinting of GTO publications is by permission only. Copyright infringement is a violation of federal law.

Mighty Mule®, E-Z Gate®, GTO®, are registered trademarks of GTO, Inc. America's DIY Automatic Gate Openers is a trademark of GTO, Inc. and are the exclusive property of GTO, Inc. ("GTO"). All rights are reserved by GTO, and these marks may not be used, in any for without the prior, written permission of GTO.